

RWC / RWR 60 ÷ 280

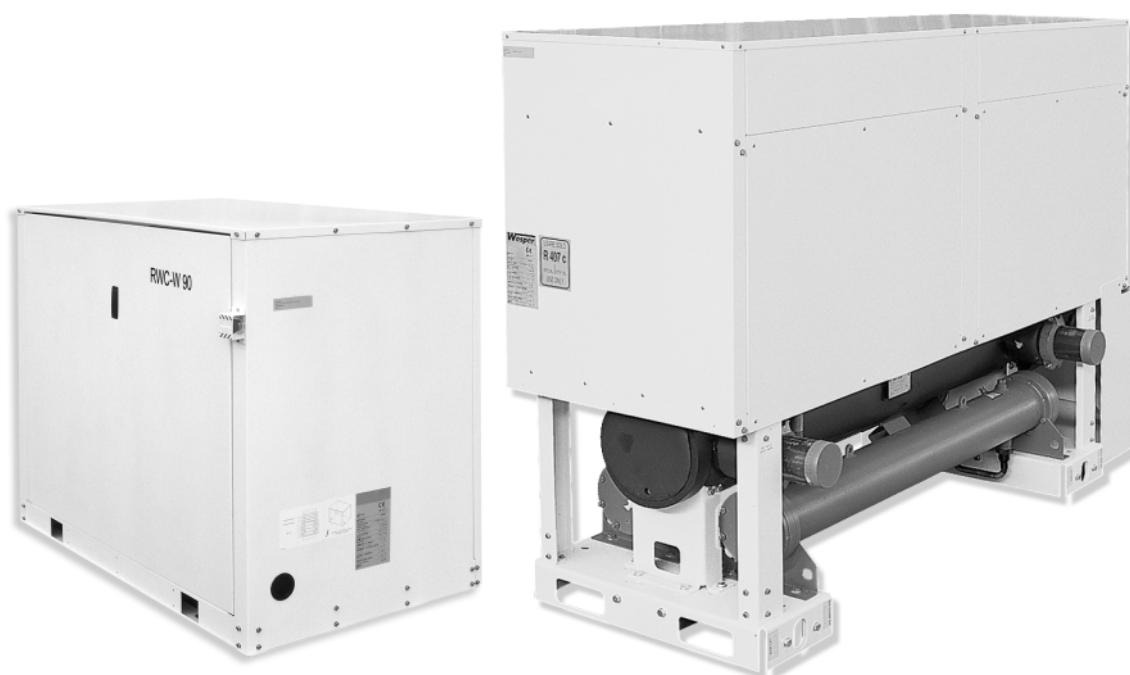

Français

English

 57
↓
243 kW
HFC 407C

Refroidisseurs de liquide à condensation par eau, refroidisseurs de liquide à condenseur à air séparé.

Water Cooled Water Chillers, Remote Air Cooled Water Chillers.

 59
↓
261 kW
HCFC 22

IOM 02 RWC.1FGB-W

Date : Septembre 2002 / September 2002

Annule et remplace / Supersedes : Néant / None



Table of Contents

1 SUPPLIER INFORMATION		4 INSTALLATION	
1.1 Introduction	3	4.1 Location	15
1.2 Warranty	3	4.2 Evaporator External Water System	15
1.3 Safety	3	4.3 Condenser External Water System	16
1.4 Emergency Stops/Shutdown	4	4.4 Water Connections	17
1.5 About this Manual	4	4.5 RWR Refrigerant Connections	17
1.6 Safety Labels	5	4.6 Electrical Supplies	18
1.7 Material Safety Data	6	4.7 Electrical Connections	18
2 PRODUCT DESCRIPTION		5 COMMISSIONING	
2.1 Introduction	9	5.1 Preliminary Checks	21
2.2 General Specification	10	5.2 Refrigerant Charging RWR Units	21
2.3 Compressors	10	5.3 Starting	21
2.4 Refrigerant Circuits	10	5.4 Performance Check	21
2.5 Evaporators and Condensers (Models 60 to 150)	10	5.5 Customer Handover	22
2.6 Evaporator (Models 170 to 280)	10	6 OPERATION	
2.7 Condensers (Models 170 to 280)	10	6.1 Control Panel	24
2.8 Power and Controls	11	6.2 Unit Starting	24
2.9 Theory of Operation	11	6.3 Water Temperature Display	24
2.10 Nomenclature	12	6.4 Alarm Display and Reset	25
3 TRANSPORTATION, HANDLING AND STORAGE		6.5 Unit Shutdown	25
3.1 Inspection	13		
3.2 Handling	13		
3.3 Anchorage	14		
3.4 Storage	14		

7	MAINTENANCE	
7.1	General Requirements	26
7.2	Daily Maintenance	26
7.3	Refrigerant Charge	27
7.4	Compressors	27
7.5	Filter Drier	27
7.6	Sight Glass	27
7.7	Thermostatic Expansion Valve	28
7.8	Evaporator(i)	28
7.9	Condensers	28
8	TROUBLE SHOOTING	29
9	TECHNICAL DATA	
9.1	Pressure Drop Graphs	31
9.2	Safety Switch Settings	34
9.3	Operational Limits	34
9.4	Physical Data	35
9.5	Unit Electrical Data	36
9.6	Compressor Electrical Data	36
9.7	Sound Power Levels	37
9.8	Space Requirements	37
9.9	Dimensions	38
9.10	Process and Instrumentation Diagrams	41
10	SPARE PARTS	
10.1	Recommended Spares	43
10.2	Recommended Compressor Oils	43
11	DE-COMMISSIONING, DISMANTLING AND DISPOSAL	
11.1	General	44

1 SUPPLIER INFORMATION

1.1 Introduction

RWC and RWR Series chillers are manufactured to the most stringent design and construction standards to ensure high performance, reliability and adaptability to all types of air conditioning installations. The unit is intended for cooling water or Glycol and is not suitable for purposes other than those specified in this manual.

If the unit is used improperly, or for different purposes without our prior agreement, then such use would be outside the scope and may be unsafe.

This manual contains all the information required for correct installation and commissioning of the unit, together with operation and maintenance instructions. The manual should be read thoroughly before attempting to operate or service the unit.

With the exception of the operations detailed in this manual, all installation, commissioning and maintenance tasks must be performed by suitably trained and qualified personnel from an Authorised Service Centre.

The manufacturer is not liable for injury or damage resulting from incorrect installation/commissioning or operation, insufficient maintenance and/or failure to follow the procedures and instructions contained in this manual.

1.2 Warranty

The unit is supplied finished, tested and ready to work. The unit warranty will be void if any modification to the unit is carried out without written agreement of the manufacturer.

For warranty purposes, the following conditions must be satisfied:

- The initial start of the unit must be carried out by trained personnel from an Authorised Service Centre.
- Maintenance must be carried out by properly trained personnel.
- Only genuine spare parts must be used.
- All the scheduled maintenance operations detailed in this manual must be performed at the specified times.

Failure to satisfy any of these conditions will automatically void the warranty.

1.3 Safety

The installation of the unit must be carried out according to the Machinery Safety Directive (CEE 98/37), to the Low Voltage Directive (73/23/EEC), to the Electromagnetic Interference directive (89/336/EEC) as modified by Directive (92/31/EEC) and according to normal rules for technical matters prescribed by the applicable country regulations. Do not operate the unit before having observed all the above.



The unit must be earthed and no installation or maintenance work should be attempted on the electrical equipment without first switching off and isolating the main power supply and any control supplies.

Failure to observance of the above safety measures may result in fire or electrocution should a short-circuit occur.



The unit contains refrigerant vapour and liquid under pressure within the heat exchangers, compressors and pipework. release of refrigerant can be a danger and cause injury.



It is the responsibility of the user to ensure that the unit is suitable for the conditions of use and that installation and regular maintenance is carried out by personnel with the appropriate skills and in accordance with this manual.



Support of the unit must be provided as indicated in this manual, failure to provide proper support may put personnel at risk of injury.



The unit is not designed to withstand loads or stresses from adjacent equipment, pipework and structures. Any such extraneous loads or stress may cause failure or collapse which can be a danger and cause injury. In such cases the warranty will be void.



Do not discard or burn the packaging in the environment.

1.5 About this Manual

For safety reasons, the instructions contained in this manual must be followed categorically; furthermore, damage caused by misuse is not covered by the warranty.

This manual uses the following conventions:



Warning messages alert you to a specific procedure or practice which, if not followed correctly, could cause serious personal injury.



Caution messages appear before procedures which, if not observed, could result in damage to the unit.



Notes contain particularly important comments which are set off from the text.

The contents of this manual, and any other document supplied with the unit, are the property of the manufacturer which reserves all rights. They may not be reproduced, in whole or in part, without the written authorisation of the manufacturer.

1.4 Emergency Stops/Shutdown

Models 60 to 150

The ganged master switch adjacent to the control panel will shutdown the unit when it is set to the 0 position.

Models 170 to 280

The isolator switch on the electrical panel will shutdown the unit when the lever is pulled downwards.

1.6 Safety Labels

The following labels are fitted to each unit.

Refrigerant Identification Label



Unit Identification Label

CE				
MODELLO MODEL	<input type="text"/>			
MATRICOLA SERIAL NUMBER	<input type="text"/>			
CARICA REFR. REFRIGERANT CHARGE	<input type="text"/>			
DATI ELETTRICI ELECTRICAL DATA	<table border="1"> <tr> <td>V</td> <td>ph</td> <td>Hz</td> </tr> </table>	V	ph	Hz
V	ph	Hz		
ALIM. POTENZA MAIN SUPPLY	400 3 50			
CORRENTE DI SPUNTO ISA	A			
CORRENTE A PIENO CARICO FLA	~ A			
POTENZA ASSORBITA POWER INPUT	~ Kw			
PRESS. ESERC. ACQUA WATER OPERATION PRESSURE	~ bar			
MASSA WEIGHT	Kg			

Electrical Warning Label

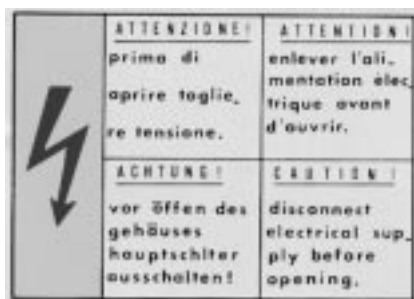

Crankcase Heater Warning Label

ATTENZIONE

INSERIRE LE RESISTENZE DI RISCALDAMENTO OLIO ALMENO 12 ORE PRIMA DI OGNI AVVIAMENTO.

PRIMA DELLA MESSA IN TENSIONE ASSICURARSI CHE LE VITI DEI CIRCUITI ELETTRICI SIANO SERRATE COMPLETAMENTE.

WARNING

ENERGIZE THE CRANKCASE HEATER FOR AT LEAST 12 HOURS BEFORE EACH STARTING.

BEFORE TIGHTENING-UP, TO TIGHTEN ALL TERMINAL SCREWS ESPECIALLY THOSE IN MAIN CIRCUIT.

881000215/B

Test Certificate

CERTIFICATO DI COLLAUDO PRODUZIONE ITELCO-CLIMA
ITELCO-CLIMA PRODUCTION TEST CERTIFICATE
UNITA' ARIA-ARIA/ARIA-ACQUA - SEMICENTRALI - CHILLER AIR/AIR/AIR/WATER

PROGR. COLL. NUMBER CHECK	DESCRIZIONE DEI TEST DESCRIPTION OF QUALITY CHECK	TIMBRO OPERAT. INSP. CODE
01	VERIFICA ASSEMBLAGGIO VERIFY ASSEMBLY COMPLETE	
02	VERIFICA VISIVA CABLAGGIO COLLEG. ELETTRICI E CONNESSIONE VERIFY WIRING CONNECTIONS	
03	VUOTO E CARICA REF. VACUUM AND CHARGE TEST	
04	VERIFICA CON CERCAFUGHE TENUTA CIRCUITO FRIGORIFERO REFRIGERANT LEAK TEST	
05	PROVE FUNZIONALI CON RILIEVI TEMPERATURA/PRESSIONI-RUMORE FUNCTION AND RUN TEST NOISE TEST	
06	VERIFICA INTERVENTI SICUREZZE PRESSIONE E TEMPERATURA CHECK OPERATION AND SAFETY DEVICES	
07	VERIFICA TENUTA CIRCUITO IDR. E FUNZIONAMENTO POMPA (SU PACCHETTO) HYDRAULIC CIRCUIT TEST (PUMP CHECK ONLY FOR PACK UNIT)	
08	VERIFICA MONTAGGIO ACCESSORI (SE PREVISTI) E DOCUMENTAZIONE CHECK ACCESSORIES/DOCUMENTATION	
09	CONTROLLO ESTETICO FINALE E PULIZIA INTERNA VISUAL CHECK FOR DIRT AND DAMAGE	

1.7 Material Safety Data

Refrigerant Data:		
Safety Data	R22, R407C	
Toxicity	Low.	
In contact with skin	In contact with skin Liquid splashes or spray may cause freeze burns. Unlikely to be hazardous by skin absorption. R22 may be slightly irritant and liquid has a degreasing effect. Thaw affected areas with water. remove contaminated clothing carefully - may adhere to skin in case of freeze burns. Was affected areas with plenty of warm water. If symptoms occur (irritation or blistering) obtain medical attention.	
In contact with eyes	Vapour has no effect. Liquid splashes or spray may cause freeze burns. Immediately irrigate with eyewash solution or clean water for at least 10 minutes. Obtain immediate medical attention.	
Ingested	Highly unlikely to occur—but should this occur freeze burn will occur. Do not induce vomiting. provided patient is conscious, wash mouth with water and give about 250 ml (0.5 pint) to drink. obtain immediate medical attention.	
Inhalation	R22: High levels of vapour concentration initially produce stimulation and then depression of the central nervous system causing headaches and giddiness and may lead to unconsciousness. can prove suddenly fatal if the exposure has been severe.	R407C: High atmospheric concentrations may lead anaesthetic effect, including loss of consciousness. very high exposures may cause an abnormal heart rhythm and prove suddenly fatal.
	At higher concentration there is a danger from asphyxiation due to reduced oxygen content of atmosphere. Remove patient to fresh air, keep warm and at rest. Administer oxygen if necessary. apply artificial respiration if breathing has ceased or shows signs of failing. In event of cardiac arrest apply external cardiac massage. Obtain immediate medical attention.	
Further Medical Advice	Symptomatic and supportive therapy is indicated. Cardiac sensitisation has been described which may, in the presence of circulating catecholamines such as adrenalin, give rise to cardiac arrhythmias and subsequent arrest following exposure to high concentrations.	
Long term exposure	R22: A lifetime inhalation study in rats and mice give a small excess in salivary gland tumours in male rats only at 50,000 ppm. 10,000 ppm showed no effect. This information suggests that R22 does not represent a carcinogenic hazard to humans.	R407C: A lifetime inhalation study in rats has shown that exposure to 50,000 ppm resulted in benign tumours of the testis. This is not considered to be of relevance to humans exposed to concentrations at or below the occupational exposure limit.
Occupational exposure limits	R22: Recommended limit: 1000 ppm v/v - 8 hr TWA, 1250 ppm v/v - 12 hr TWA	R407C: Recommended limit: 1000 ppm v/v - 8h hr TWA.
Stability	R22: Instable	R407C: Not specified
Conditions to avoid	Use in presence of naked flames, red hot surfaces and high moisture levels.	
Hazardous reactions	May react violently with sodium, potassium, barium and other alkali and alkaline earth metals. incompatible materials: Magnesium and alloys containing more than 2% magnesium.	
Hazardous decomposition products	R22: Halogen acids formed by thermal decomposition.	R407 C: Halogen acids by thermal decomposition and hydrolysis.
General precautions	Avoid inhalation of high concentrations of vapors. Atmospheric concentrations should be minimised and kept as low as reasonably practicable below the occupational exposure limit. The vapour is heavier than air and collects at low level and in confined areas. Ventilate by extraction at lowest levels.	

Respiratory protection	Where doubt exists on atmospheric concentration, HSE approved breathing apparatus should be worn. This should be self contained or of the long breather type.	
Storage	Keep containers dry and in a cool place away from fire risk, direct sunlight, and all sources of heat such as radiators. Keep at temperatures not exceeding 45 °C.	
Protective clothing	Wear overalls, impervious gloves and goggles/face protection.	
Spill / Leak procedure	Ensure suitable personal protective clothing and respiratory protection is worn. Provided it is safe to do so, isolate the source of the leak. Allow small spillage's to evaporate provided there is suitable ventilation. Large spillage's: Ventilate area. Contain spillage's with sand, earth or any suitable absorbent material. Prevent liquid from entering drains, sewers, basements and work pits since vapour may create a suffocating atmosphere.	
Disposal	Best to recover and recycle. If this is not possible, destruction is to be in an approved facility which is equipped to absorb and neutralise acids and other toxic processing products.	
Fire extinguishing data	R22: Non-flammable.	R407C: Non-flammable at atmospheric conditions.
Containers	Fire exposed containers should be kept cool with water sprays. Containers may burst if overheated.	
Fire fighting protective equipment	Self contained breathing apparatus and protective clothing must be worn in fire conditions.	

Refrigerant Oil Data:	
Safety Data	Oil
Classification	Non-hazardous.
In contact with skin	Minimally irritating. No first aid necessary. Exercise reasonable personal cleanliness including cleansing exposed skin areas several times daily with soap and water. Launder soiled work clothes at least weekly.
In contact with eyes	As with most foreign materials flush with plenty of eyewash solution or clean water.
Ingested	Obtain immediate medical attention.
Inhalation	Obtain immediate medical attention.
Conditions to avoid	Strong oxidisers, caustic or acid solutions, excessive heat. May degrade some paints and rubber materials.
Respiratory protection	Use in well ventilated areas.
Protective clothing	Goggles or face shield should be worn. Gloves not necessary, but recommended, especially for prolonged exposure.
Spill / Leak procedure	Wear suitable protective equipment, especially goggles. Stop source of spill. Use absorbent materials to soak up fluid (i.e. sand, sawdust, and commercially available materials).
Disposal	Incinerate the oil and all associated wastes in an approved facility in accordance with local laws and regulations governing oily wastes.
Fire extinguishing data	Use dry chemical, carbon dioxide or foam spraying water on hot or burning liquid, may cause frothing or splashing.
	If a leak or spill has not ignited use water spray to disperse the vapours and to provide protection for persons attempting to stop the leak.
Containers	Fire exposed containers should be kept cool with water sprays.
Fire fighting protective equipment	Self contained breathing apparatus should be worn in fire conditions.

- 1 Compressor Compartment
- 2 Power Compartment
- 3 Control Compartment
- 4 Evaporator
- 5 Condenser
- 6 Cable Entry

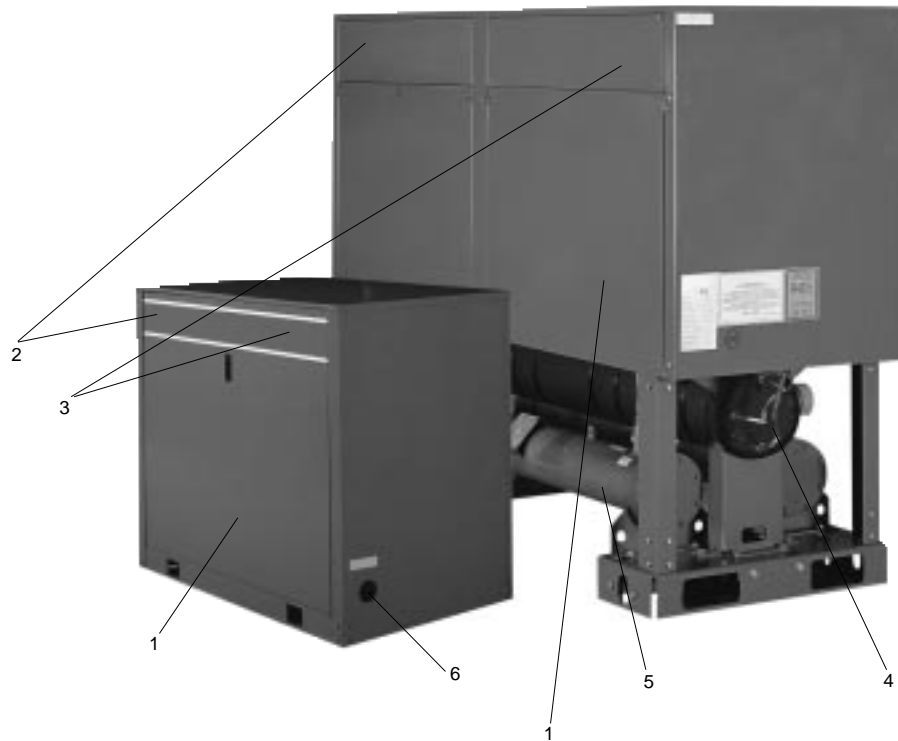

2 PRODUCT DESCRIPTION

2.1 Introduction

The RWC/RWR range of twin refrigerant circuit water chillers are designed to be located inside the plant room of a building. RWC chillers require a cooling tower or dry cooler for heat rejection. RWR chillers require a remote air cooled condenser for heat rejection.

The range includes the following models:

Models	Description
RWC 60 to 280	Water Cooled chillers charged with refrigerant R22
RWC/B 60 to 280	Water Cooled chillers charged with refrigerant R407C
RWR 60 to 280	Remote Air Cooled chillers charged with refrigerant R22
RWR/B 60 to 280	Remote Air Cooled chillers charged with refrigerant R407C

The following options are available:

Option	Description
Acoustic Kit (sizes 170-280)	A factory installed kit using acoustically lined compressor enclosure and compressor acoustic covers.
Remote Control Kit	A field mounted control panel to provide remote control.
Pressure Gauge Kit (sizes 170-280)	Factory fitted mechanical gauge kit for display of unit operating parameters.
Manifold Kit	Field mounted manifolds to provide a single point of connection for leaving and return water circuits.
Flow Switch Kit	Field mounted flow switches for evaporator water circuits

2.2 General Specification

RWC models are completely assembled with all interconnecting refrigerant piping and wiring ready for field installation. After assembly a full run test is performed, with water flowing through the evaporators, to verify that each refrigerant circuit operates correctly.

RWC units are pressure tested, evacuated and fully charged with refrigerant and include an initial oil charge.

RWR (motoevaporative) units are pressure tested, evacuated and nitrogen holding charge and initial oil charge.

The unit base and frame is of heavy gauge galvanized steel fastened with stainless steel screws and bolts. All panels are easily removed for access to components. Galvanized steel parts are painted with baked-on enamel coloured white (RAL 9001).

2.3 Compressors

The hermetic compressors have internal motor protection and an internal overflow valve from discharge to suction. Starting is direct on line. The compressors are mounted on rubber anti-vibration pads and housed in a separate acoustically lined enclosure.

Compressor lubrication is force-fed by a reversible oil pump to all crankshaft and bearing surfaces through a fine mesh stainless steel oil strainer.

The compressor motors are refrigerant gas cooled, with integral thermistor protection against overloads. The overload protection is automatically reset after approximately 8 seconds. The motor terminal boxes are to IP-54 weather protection.

The compressors are switched On and Off by the unit microprocessor to provide capacity control.

2.4 Refrigerant Circuits

Two complete refrigerant circuits are supplied on each unit. All piping is ACR copper, with brazed joints. Refrigerant circuits include: a service valve for refrigerant charging, suction discharge and liquid line isolating valves, a sight glass with moisture indicator and thermostatic expansion valve. High and low pressure switches and a filter/drier are also included.

2.5 Evaporators and Condensers (Models 60 to 150)

Each of the two evaporators and condensers is a stainless steel plate type heat exchanger thermally insulated with flexible closed cell material. Design working pressure is 10 bar g on the water side and 30 bar g on the refrigerant side. An electric heater mat and differential pressure switch are provided.

Each exchanger is provided with flow and return water connections. Water connection is via 1 inch gas threaded connections on models 60 and 75 and 1-1/2 inch gas threaded connections on models 90 to 150.

2.6 Evaporator (Models 170 to 280)

The single dual-circuit steel shell and copper tube evaporator is a direct-expansion type. It has refrigerant in the tubes, which are formed in a hairpin configuration, and chilled liquid flowing through the baffled shell. The evaporator is covered with flexible, closed-cell, foam insulation.

Water connection to the evaporator is via Victualic type connections. The evaporator has a heating element controlled by a thermostat. Water vent and drain connections are included on the evaporator.

The evaporator design working pressure on the water side is 10 bar g and 30 bar g on the refrigerant side.

2.7 Condenser (Models 170 to 280)

The condensers are shell and tube type with a built-in sub-cooler and removeable water heads. The design working pressure on the water side is 10 bar g and 30 bar g on the refrigerant side.

2.8 Power and Controls

All controls and motor starting equipment necessary for full unit operation are factory wired and tested. The power and control components are separated within the panel, which is designed to IP-54 weather protection.

Power Compartment

The power compartment contains compressor contactors, fuses and supply protection.

Control Compartment

The control compartment contains an electronic circuit board and a soft touch key control panel with display of operating functions, alarms and stops.

2.9 Theory of Operation

RWC Cooling Mode

Low pressure liquid refrigerant enters the cooler (Evaporator) and is evaporated and superheated by the heat energy absorbed from the chilled water passing through the cooler shell. Low pressure vapour enters the compressor where pressure and superheat are increased. Heat is rejected by the water cooled condenser. The fully condensed and subcooled liquid refrigerant then enters the expansion valve where pressure reduction and further cooling takes place before returning to the cooler.

RWR Cooling Mode

The operation of the RWR is identical to the RWC except for the water cooled condenser which is replaced by a remote air cooled condenser.

Models RWC 60 to 150

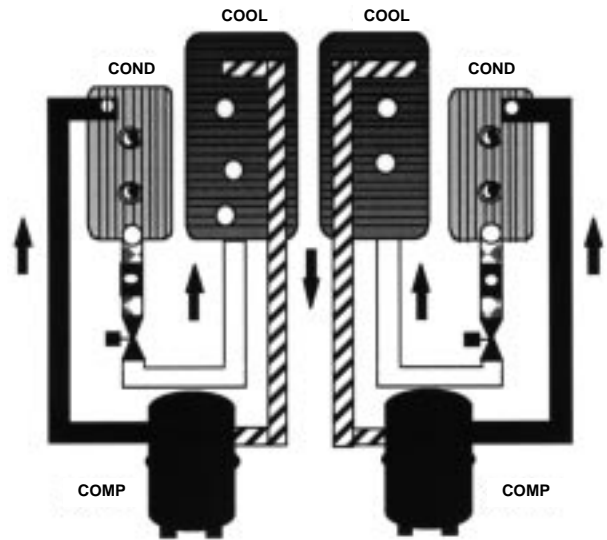

Models RWC 170 to 280

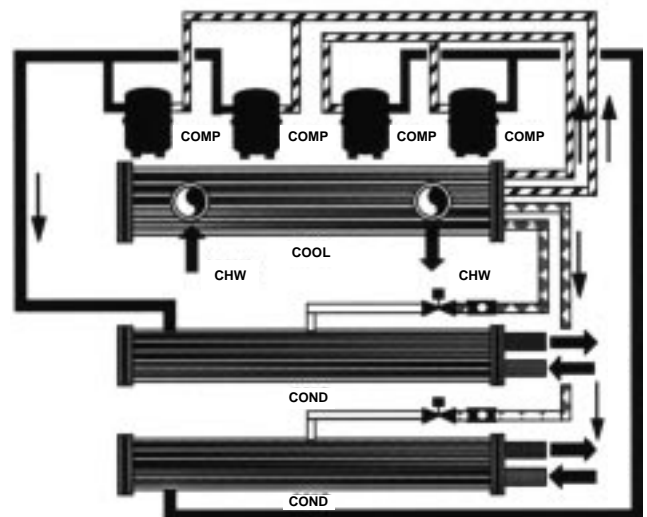

2.10 Nomenclature

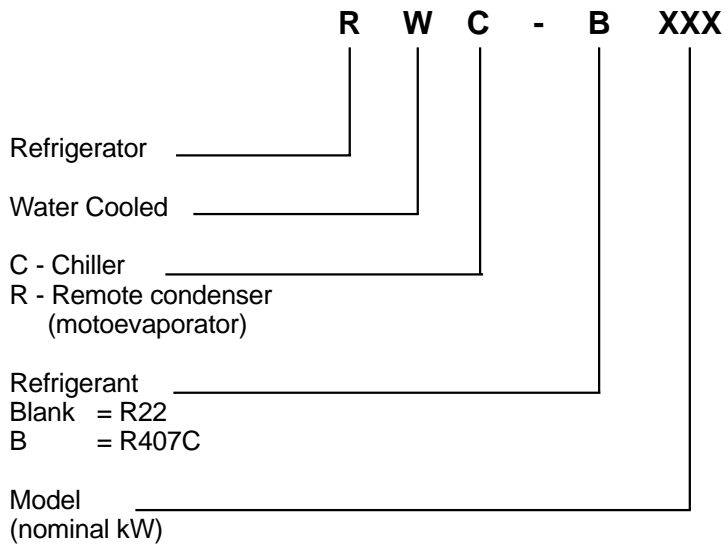

3 TRANSPORTATION, HANDLING AND STORAGE

RWC/RWR series chillers are supplied fully assembled.

RWC units are pre-charged with refrigerant and oil in the correct quantity required for operation.

RWR units include a nitrogen holding charge and are pre-charged with oil in the correct quantity required for operation.



The refrigerant circuits on RWR unit have to be charged before the unit is operated.

3.1 Inspection

Immediately upon receiving the unit, it should be inspected for possible damage which may have occurred during transit as goods are shipped exworks at purchaser's risk. In addition, ensure that all ordered components have been received.

If any damage is evident, it should be noted on the carrier's freight bill and a claim entered in accordance with the advice note instructions. If the damage is other than superficial, immediately advise your local representative.

The manufacturer accepts no responsibility for shipping damage, even in cases where the factory has arranged for shipping.

3.2 Handling

Models 60 to 150 are designed to be lifted using a fork lift truck.

Models 170 to 280 are designed to be lifted using lifting lugs and cables. A spreader bar or frame should be used with the cables, to avoid damaging the unit.

Before moving the unit ensure that the installation site is suitable to receive the unit and to support its weight and mechanical impact.

During handling the unit should not be inclined from the vertical.

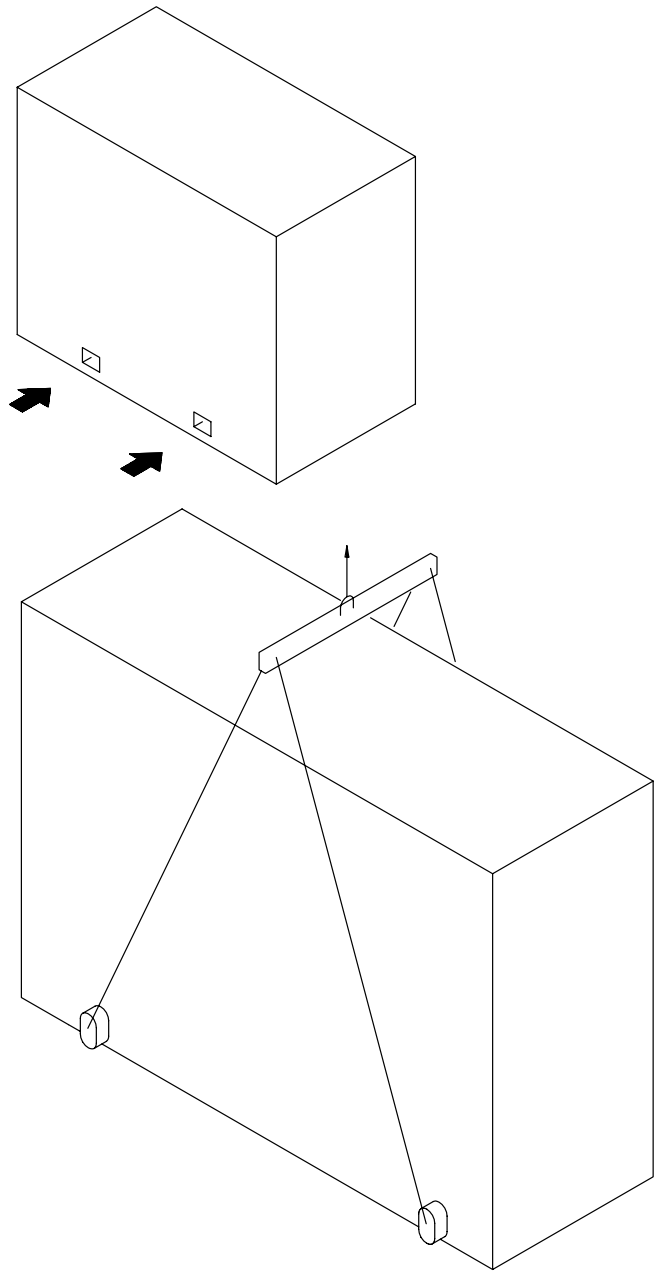

Care should be taken to avoid damaging the paneling when lifting and moving the unit to the installation site. The sides of the unit should be protected with stiff cardboard or plywood.



Do not remove the protective packaging until the unit is ready for operation.

3.3 Anchorage

RWC/RWR series chillers are provided with 18 mm diameter holes in the base frame for retaining the unit if required.

3.4 Storage

If the unit is to be stored prior to installation, certain precautions should be taken to prevent damage, corrosion or deterioration:

- Ensure that all openings, such as water connections, are securely capped or sealed.
- Do not store where exposed to ambient air temperatures exceeding 45°C for R22 or 42°C for R407C units, preferably out of direct sunlight.
- Store the unit in a location where minimum activity is likely to take place to limit the risk of accidental damage.
- Do not steam clean the unit.
- Remove the keys necessary to gain access to the control panel and deposit them with a responsible person on site.

Periodic visual examination during storage is recommended.

4 INSTALLATION

4.1 Location



Before installing the unit, make sure that the building structure and/or mounting surface can support the unit weight. Overall weights are detailed in Section 9.

The unit has been designed for floor mounting in protected indoor locations.

The installation site should ensure adequate clearances and drainage for maintenance, refer to Section 9 for details.

4.2 Evaporator External Water System



The external water hydraulic circuit must ensure constant water flow to the evaporator(s) under all operating or adjustment conditions.

The external water system should consist of the following:

- A circulation pump providing sufficient flow and hydraulic head.
- The primary system water content should be no less than 10 litres per kW of cooling capacity. If the total volume in primary system pipework and evaporator is insufficient, an insulated reservoir tank should be installed. This tank will ensure that repetitive starts of the compressors are avoided.
- A diaphragm-type expansion tank with safety valve outlet which must be visible.



The tank should be sized to accommodate a 2% increase in total fluid volume in the system (evaporator, lines, user circuits and reservoir tank where provided). The expansion tank does not need to be insulated, as water does not normally circulate therein.

- A flow switch to deactivate the unit when water is not circulating.



The flow switch must be connected in series with other external interlocks. The flow switch should be installed on the pump delivery, upstream of the unit.

A Normally Open differential pressure switch may be installed instead of the flow switch. The pressure switch senses water pressure drop across the evaporator.

In addition:

- Install a filter/strainer on the inlet side of the evaporator(s).
- Install shutoff valves on the evaporator(s) inlet and outlet water lines.
- Install a valved by-pass around the evaporator(s).
- Install air vent valves at the highest points of the lines.
- Provide suitable drainage points (with plugs, cocks etc.) at the lowest points of the lines.
- Insulate the pipework to prevent heat loss.

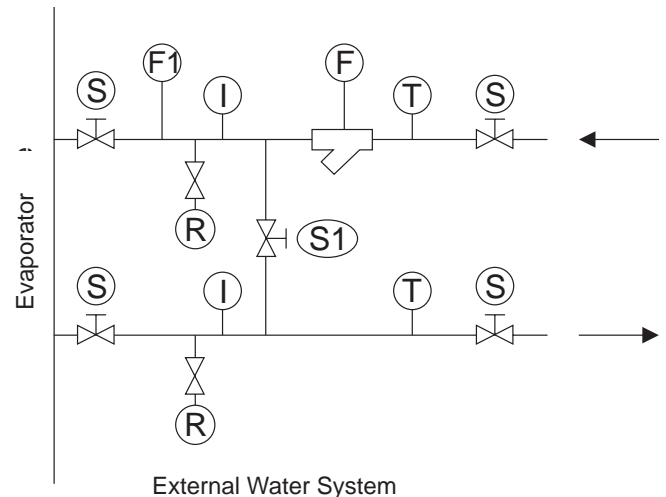

Key

I	Pressure	R	Drain tap
T	Temperature	F	Strainer
S	Gate valves	F1	Flow switch
S1	By-pass valve		



Before filling the system, ensure that it is free from foreign matter, sand, stones, rust flakes, solder, slag or other materials which could damage the evaporators.

It is advisable to by-pass the unit when flushing out the lines.



Water used to fill the circuit may have to be treated to ensure that the pH value is correct.

Standard evaporators provided on RWC/RWR units are designed to chill mixtures of water and ethylene glycol with a corrosion-inhibiting additive down to -10 °C (R22) and -5 °C (R407C).

The amount of ethylene glycol to be added is as follows.

Amounts are shown as a percentage by weight of the circuit design water content:

operation from + 5 to 0 °C : 20%

operation from 0 to -5 °C : 30%

operation from -5 to -10 °C : 40%

4.3 Condenser External Water System



The external water hydraulic circuit must ensure constant water flow to the condensers under all operating or adjustment conditions.

For cooling of RWC units, condensers are usually piped in conjunction with a cooling tower, although in some cases they can be cooled by well water.

With water cooled units it is necessary to control coolant flow and/or temperature into the condenser to maintain refrigerant pressure constant to ensure satisfactory operation.

For a cooling tower system the simplest forms of control are to use fan cycling, fan speed control, or air damper control, with the tower having a thermostat in its sump.

If these methods are not available, or a cooling tower is not the source of cooling water, then a three way valve recirculation system can be used.

The external water system should consist of the following:

- A circulation pump providing sufficient flow and hydraulic head.
- The primary system water content should be no less than 5 litres per kW of cooling capacity.

The water used for the condenser external water system should have a hardness value within 10 to 15 °Fr.

In addition:

- Install a filter/strainer on the inlet side of the condenser(s).
- Install shutoff valves on the condenser(s) inlet and outlet water lines.
- Install a valved by-pass around the condenser(s).
- Install air vent valves at the highest points of the lines.
- Provide suitable drainage points (with plugs, cocks, etc.) at the lowest points of the lines.

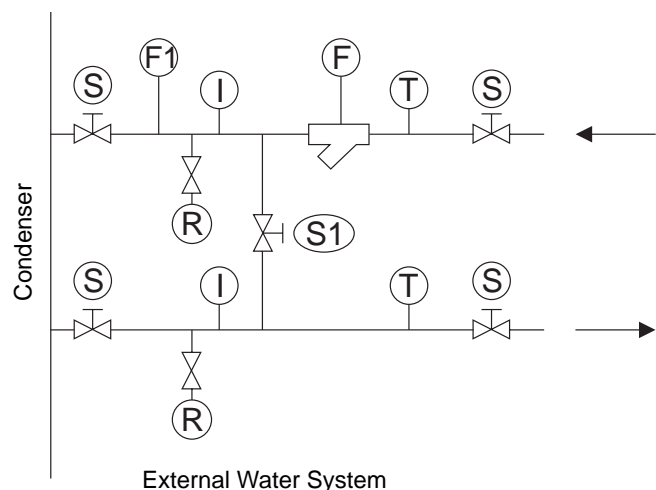

Key

- | | | | |
|----|---------------|----|-------------|
| I | Pressure | R | Drain tap |
| T | Temperature | F | Strainer |
| S | Gate valves | F1 | Flow switch |
| S1 | By-pass valve | | |

4.4 Water Connections



The water inlet and outlet connections must be connected correctly as shown on the labels fitted next to the fittings.

Connect the external water supply lines to the water inlet and outlet fittings on the unit, refer to section 9 for diameters and locations.

4.5 RWR Refrigerant Connections and Pipework Design

For cooling of RWR units, condensers are usually of the remote air-cooled type either roof or ground level mounted. Refrigerant systems should be designed and installed by suitably qualified persons in compliance with relevant national codes and standards. The complete pipework system and condenser must have a Design Working Pressure of at least 30 barg.

When the unit has been located in its final position, the refrigerant system pipework can be connected. Pipework and fittings **MUST** be separately supported and not cause any loading on the unit. Flexible connections are recommended and will also minimise transmission of vibrations to the building.

Pipework Design

The following notes give guidance but should not be considered exhaustive.

P-traps and double risers may be required when the condenser is sighted above the unit. Horizontal runs of the liquid line should be inclined slightly towards the RWR unit.

An in-line receiver should not be installed in the refrigerant system.

Where the condenser is above or level with the unit, the discharge line should rise to at least the top edge of the condenser at some point. This will prevent liquid draining back to the compressor during the off cycle.

Elbows, bends and valves should be minimised to reduce pressure drop and prevent loss of performance. The liquid line in particular should be designed for minimum pressure drop to avoid flashing in the liquid line which will cause loss of performance and fault conditions to occur. Particular care should be taken where the condenser is below or level with the unit.

Refrigerant Connections

Units are supplied with a nitrogen holding charge. This should be relieved carefully via the suction service connections and the liquid line service connections.

The pipework can be brazed directly onto the welding connections taking care to protect the unit from excess heat which may cause distortion.

System Testing

All newly installed pipework must be pressure /leak tested to national code requirements (normally 1.1 x Design Working Pressure) then fully evacuated before charging. Refer to the section 5 for correct charging methods.



Incorrectly or badly designed and/or installed pipework systems may invalidate unit warranty

4.6 Electrical Supplies



Ensure that the power supply is off before working on the electrical system.



The unit must be provided with an earth connection.



It is the installers responsibility to ensure that all external wiring complies with applicable safety regulations.

The Manufacturer is not responsible for injury or damage of any kind resulting from failure to observe these precautions.

The unit complies with EN 60204-1.

The following connections are required:

- One three-phase line and earth for the power circuit supply.

The electrical distribution system must be able to supply all the unit power, refer to Section 9.

The disconnect switches and circuit breakers must be sized to handle the unit starting current, refer to Section 9.

Supply and isolating devices shall be designed so that the lines are fully independent.

Magnetic thermal differential breakers are recommended, to prevent damage due to electrical phase loss.

Power supplies to the compressors and the fans are through contactors controlled by the control panel.

Each motor is provided with an internal thermal overload cut-out and external fuses.

Supply cables should be routed through the cable entries on the unit front and enter the electrical panel through a hole at the bottom of the panel.

4.7 Electrical Connections

The installation of the unit on the final site must be carried out according to the Machinery Safety directive (98/37/EC), to the Low Voltage Directive (73/23/EEC), to the Electromagnetic Interference directive (89/336/EEC) and according to normal rules for technical matters prescribed by the applicable country regulations. Do not operate the unit before having observed all the above. Supply lines shall consist of insulated copper conductors sized for maximum current draw.

Terminal connections should be made in accordance with the connection diagram in this manual and the diagram supplied with the unit.



Before connecting the supply lines, check that the mains voltage is within the range shown in the Electrical Data in Section 9.

For the 3 phase power supply, also check that the phase unbalance does not exceed 2%. The check is performed by measuring the difference between the voltage of each phase pair and the average mains voltage during operation. The maximum measured difference (unbalance) shall not exceed 2% of the average voltage.

If the unbalance is unacceptable, the electricity supply company must be asked to correct the fault.



Supplying the unit with a line whose unbalance exceeds the specified value will automatically void the warranty.

RWC Models 60 to 150 Electrical Connections

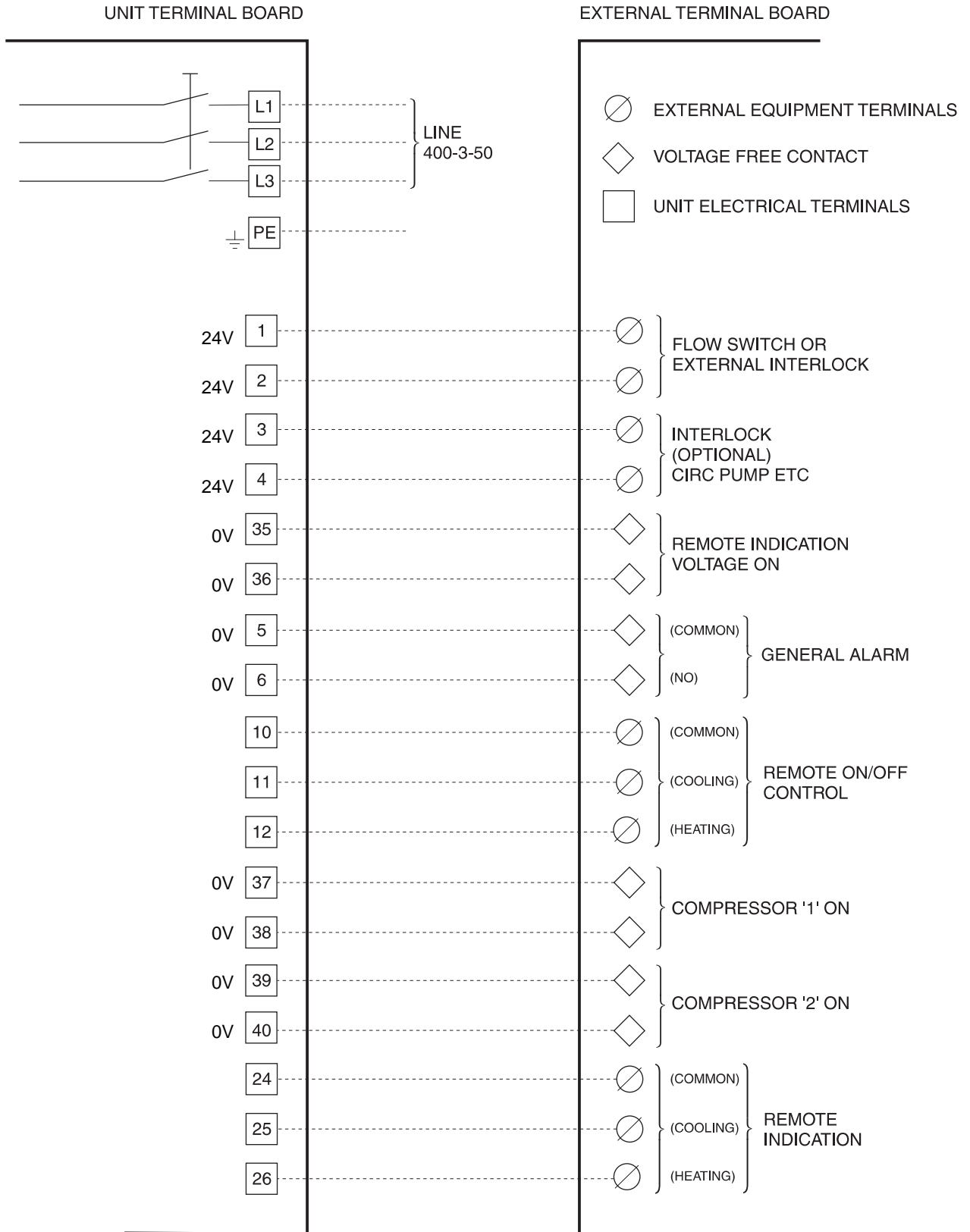

RWC Models 170 to 280 Electrical Connections

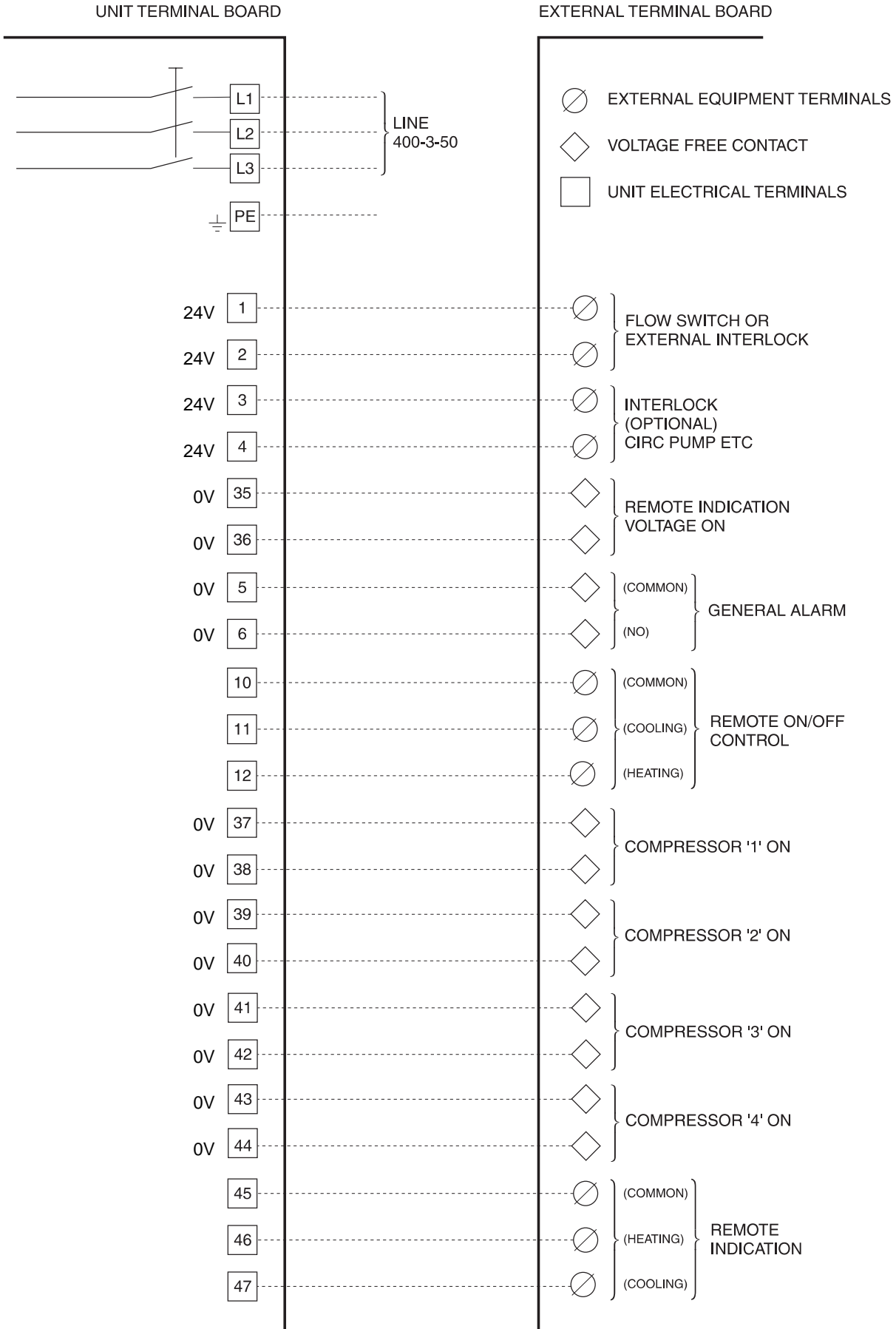

5 COMMISSIONING



The unit must be started by trained personnel from an Authorised Service Centre. Failure to satisfy this requirement will void the warranty.



The operations performed by Service personnel are limited to unit starting, and do not include other work on system such as electrical connection, water connection, etc. All other preparatory work, including oil pre-heating (for at least 12 hours) must be performed by installer.

5.1 Preliminary Checks

The following operations must be performed before starting the unit and should be performed before service personnel arrive.

- With master isolating switch off, check the supply cable cross-section, the ground connection, the electrical terminal clamps are tight and that all contactors operate correctly.
- Check that the voltage and phase unbalance of the power supply is within limits, refer to Section 4.
- Connect (non-energised) contacts of the flow switch and the pump thermal overload cut-out or other devices (where provided) to terminals 1-2 and 3-4 respectively.
- Check that the external water circuit components (pumps, user equipment, filters, expansion tank and reservoir where provided) have been correctly installed as advised by manufacturer and that the inlet and outlet water connections are correct.
- Check that the external water circuit is full and that the fluid circulates freely with no signs of leakage or air bubbles. If ethylene glycol antifreeze is used, check that the percentage concentration is correct.
- Check that the pump direction of rotation is correct, and allow fluid to circulate for at least 24 hours (12 hours for each pump). Then clean the basket filters on the pump suction.
- Adjust the water system so that the flow rates are as specified.
- Check that the water quality is as specified.
- Check that the oil heaters, if fitted have been energised for at least 12 hours.

5.2 Refrigerant Charging RWR Units

Units are supplied with a nitrogen holding charge. This should be relieved carefully via the suction service connections and the liquid line service connections.

The unit should be evacuated with a suitable vacuum pump/recovery unit as appropriate to below 100 microns.

Do not liquid charge with static water in any of the heat exchangers. Care must also be taken to liquid charge slowly to avoid excessive thermal stress at the charging point. Once the vacuum is broken, charge the unit with the full operating charge as given in the Physical Data section of this manual. Check the unit data plate and/or unit labels for the type of refrigerant to be used with the unit.

5.3 Starting

The starting sequence is as follows.

- Turn on the master isolating switch (12 hours before).
- Check that the compressor oil is sufficiently warm (minimum temperature at the oil pan exterior must be approximately 40°C) and that the auxiliary control circuit is energised.
- Check that all external equipment is in running order and that the associated control equipment is correctly calibrated.
- Start the liquid pump and check that the water flow rate is as required.
- Set the desired fluid inlet temperature on the control panel (refer to Section 6).
- Start the unit (refer to Section 6).
- After around 15 minutes of operation, check that no air bubbles are visible through the sight glass on the fluid line.



If air bubbles are visible, the unit has lost part of its charge through one or more leaks. The leaks must be eliminated refer to Section 7.

- Repeat the starting procedure after eliminating the leaks.
- Where the compressor is provided with a sight glass, check that the oil level is correct.

5.4 Performance Check

Check the following:

- Evaporator manifold inlet water temperature.
- Evaporator manifold outlet water temperature.
- Evaporator outlet water flow rate.
- Compressor current at startup and stable operating conditions.

Check that the saturated evaporation and condensation temperatures during operation at high and low pressure by connecting gauges to the schrader valves on the high and low pressure refrigerant circuits.

High pressure side	Approximately 10 to 12°C above condenser water inlet temperature.
Low pressure side	Approximately 5 to 7°C below chilled water outlet temperature

5.5 Customer Handover

- Familiarise the user with the machine operating instructions in Section 6.

6 OPERATION

RWC/RWR series chillers are equipped with an electronic control and monitoring system as standard. The system provides control, monitoring and alarm functions.

The system consists of an electronic circuit board and a control panel with display and touch keys.

Control functions:

- Unit capacity control.
- Compressor startup delay.
- Anti-freezing protection.

Alarm management and display

- High pressure alarm.

When the alarm is activated, the control system locks out the associated refrigerating circuit and opens the compressor control chain (fail-safe mode). The alarm is reset from the pressure switch and manually from the panel.

- Low pressure alarm.

When the alarm is activated, the control system locks out the associated refrigerating circuit. Alarm operation is delayed approximately 30 seconds after starting. Alarm is reset manually from the panel.

- Anti-freezing alarm.

This alarm is activated when water temperature at evaporator outlet drops below 3 °C. The control system locks out the associated refrigerating circuit. Alarm is reset manually from the panel.

- External interlock alarm.

When the alarm is activated, the control system locks out the unit. Reset is automatic.

Control Panel

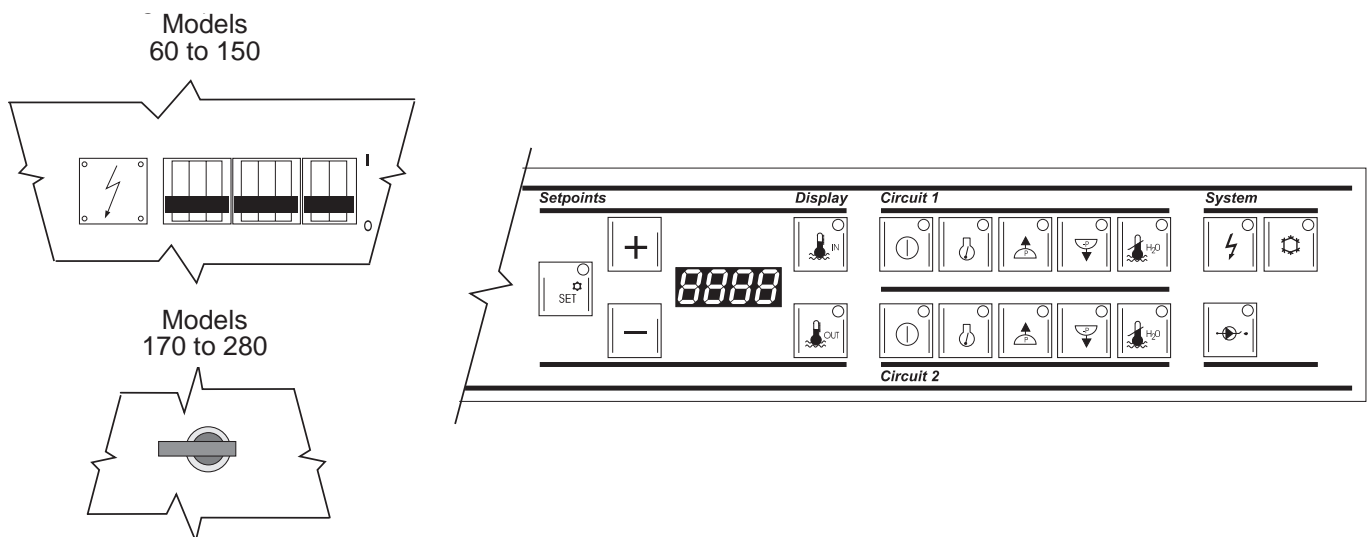

6.1 Control Panel

Item	Function
	Displays operating and fault parameters.
	SET POINT + key (increases temperature SET POINT).
	SET POINT - key (reduces temperature SET POINT).
	SET POINT display key.
	Circuit 1 or 2 power key and LED (Select circuit 1 or 2).
	Circuit 1 or 2 compressor ON LED
	Circuit 1 or 2 high pressure alarm LED. Indicates that high pressure switch for circuit 1 or 2 has been activated.
	Circuit 1 or 2 low pressure alarm LED. Indicates that low pressure switch for circuit 1 or 2 has been activated.
	Voltage indicator LED. Indicates that unit is connected to power supply.
	Circuit 1 or 2 anti-freezing alarm LED. Indicates that water temperature at evaporator outlet is below safe limit.
	External interlock alarm LED.
	Warm weather mode start key and LED. Starts the unit in the cooling mode. Led lights up to indicate operating in cooling mode.

6.2 Unit Starting

To start the unit proceed as follows:

- Set the master switch to the on (I) position to energise the control panel.

Check that LED (voltage indicator) goes on.

Check that there are no active alarm signals.

- Activate the two circuits for operation by pressing the key for each circuit.

The unit is now in stand-by, the display will come on and the LED's for the associated circuits will flash for approximately 15 seconds before coming on.

If necessary, set the water temperature as follows:

- Press the set point display key to display the unit set point on the display.
- Change the unit set point using the key to the key to decrease the temperature.

The unit set point is factory set to 12°C for warm weather operation and 45 °C for cold weather operation.

- Press the key to start the unit in the cooling mode.

The LED will go on.

Compressor operation will be indicated by LED's for each circuit

6.3 Water Temperature Display

To display the evaporator inlet water temperature press the key.

To display the evaporator outlet water temperature press the key.



6.4 Alarm Display and Reset

Alarms are indicated by the associated panel LED's and by messages on the display. Details of the alarm codes are given below.

E01	Sensor Failure Inlet Water Temperature Sensor (Evaporator)
E02	Sensor Failure Outlet Water Temperature Sensor (Evaporator Circuit 1)
E03	Sensor Failure Temperature Sensor (Condenser Inlet)
E04	Sensor Failure Outlet Water Temperature Sensor (Evaporator Circuit 2)
E05	Sensor Failure Outlet Water Temperature Sensor (Condenser Circuit 2)
E06	Circuit 1 Anti Freezing
E07	Circuit 2 Anti-Freezing
E08	Sensor Failure Outlet Water Temperature Sensor (Condenser Circuit 2)
E09	High Pressure Circuit 1
E10	High Pressure Circuit 2
E13	External Interlock
E14	Low Pressure Circuit 1
E15	Low Pressure Circuit 2

6.5 Unit Shutdown

To shutdown the unit proceed as follows:

- Press the  to return the unit to stand-by.
- De-activate the two circuits by pressing the  key for each circuit.
- Turn master isolating switch to OFF position to de-energise the unit.

7 MAINTENANCE



Never release refrigerant to the atmosphere when emptying the refrigerating circuit. Suitable retrieval equipment must be used. If reclaimed refrigerant cannot be re-used. It must be returned to the manufacturer.



Never discard used compressor oil, as it contains refrigerant in solution. Return used oil to the oil manufacturer.

The Safety Section of this manual should be read carefully before attempting any maintenance operation on the unit.

Unless otherwise indicated, the maintenance operations described below can be performed by any properly trained maintenance technician.

7.1 General Requirements

The RWC range has been designed to work continuously provided they are regularly maintained and operated within the limitations given in this manual. Each unit should be maintained in accordance with the schedule by the operator/customer, backed up by regular service and maintenance visits by an authorised Service Centre.

It is the responsibility of the owner to provide for these regular maintenance requirements and/or enter into a maintenance agreement with a Service Centre to protect the operation of the unit.

If damage or a system failure occurs due to improper maintenance during the warranty period, Itelclima shall not be liable for costs incurred to return the unit to satisfactory condition.

This maintenance section applies only to the basic RWC/RWR unit and may, on individual contracts, be supplemented by additional requirements to cover any modifications or ancillary equipment as applicable.

7.2 Daily Maintenance

The maintenance checks should be carried out in accordance with the maintenance schedule detailed below by a competent person.

Please note, however, that RWC series units are not generally user serviceable and no attempt should be made to rectify faults or problems found during daily checks. If in any doubt, contact an Authorised Service Centre.

Scheduled Maintenance

Operation	Daily	Weekly	Monthly	Start of Season	End of Season
Check evaporator entering / leaving liquid temperature	●				
Check evaporator pressure drop		●			
Check condenser pressure drop		●			
Check electrical power consumption		●			
Check suction pressure and temperature		●			
Check discharge pressure and temperature		●			
Check compressor oil level		●			
Check for gas bubbles in refrigerant		●			
Check low pressure switch				●	
Check high pressure switch				●	
Check evaporator insulation				●	
Check tightness of wiring terminal screws				●	
Clean outside surface of the unit with soapy water				●	
Check specific gravity of brine (Glycol) if applicable				●	●
Drain and clean the evaporators and condensers					●

7.3 Refrigerant Charge



Never introduce liquid refrigerant in the low pressure side of circuit. Extreme care must be taken to ensure that circuit is correctly charged.

An insufficient charge will lead to poor machine performance. In extreme cases, the low pressure switch will cut in and lock the circuit.

Excessive charge will raise the condensation pressure (which in extreme cases will cause the high pressure switch to cut in and lock the circuit) with a consequent increase in power consumption.



Under no circumstances must the compressor be used as a vacuum pump to purge circuit.

The refrigerant circuit must be charged whenever it is emptied for maintenance purposes (leak repair, compressor replacement, etc.). Charge quantities are given in Section 9.

Before charging, the circuit must be vacuum-purged and dried, reaching a minimum absolute pressure of 50 Pa.

The refrigerant gas must be introduced to eliminate vacuum and to charge the circuit to 90% of the total required gas in liquid form through the appropriate charging valve on liquid line at condenser outlet.

A refrigerant container should then be connected to the charging valve on suction line, the container should be held so that only gaseous phase refrigerant is released (R22).

The compressor should be started and gas allowed to flow from the refrigerant container until liquid in the sight glass runs clear and gas temperature at evaporator outlet has stabilised at around 5°C. R407C units must be charged when the refrigerant is in the liquid phase. A service valve is provided for charging the unit at low pressure.

7.4 Compressors

Compressors are supplied with the correct quantity of lubricant required for operation. Under normal operating conditions, lubricant will last the life of the unit. Fluid top-up is not required as long as refrigerating circuit operates correctly and no repair operations have been carried out.

Compressor replacement (as a result of failure), should be carried out by an Authorised Service Centre.

7.5 Filter Drier

Refrigerating circuits are provided with filter/driers.

The filter/driers are non-inspectable strainer type. filter/drier clogging will be indicated by bubbles in the sight glass, or by a difference in temperature upstream and downstream of filter/drier.

If bubbles persist after the changing cartridge, the machine has lost part of its refrigerant charge through one or more leaks which must be identified and repaired.

7.6 Sight Glass

The sight glass is used to observe refrigerant flow and moisture content. Bubbles in flow indicate that filter/drier is clogged, or that refrigerant charge is low.

A colour indicator is located inside the sight glass. compare the colour of the indicator with the scale on the sight glass lock ring to determine the moisture content of refrigerant. If moisture content is too high, proceed as follows:

- Discharge the circuit without releasing refrigerant to the atmosphere. Vacuum-purge the circuit and replenish the charge.

7.7 Thermostatic Expansion Valve

RWC/RWR refrigerating circuits are provided with a thermostatic expansion valve with an external equaliser. valves are calibrated at the factory for a 5 °C temperature rise.

To check the temperature rise:

Read the suction using a pressure gauge connected to charging valve on suction side.

Using the pressure gauge temperature scale, determine the saturated suction temperature T_{sa} corresponding to this pressure.

Determine the effective suction temperature T_{se} using a contact thermometer applied to the evaporator gas outlet fitting.

Temperature rise S is given by:

$$S = T_{se} - T_{sa}$$

The temperature rise can be corrected using the adjuster screw on the thermostatic expansion valve. turn the adjuster screw through a single revolution and operate the unit for five minutes. Then check the temperature rise again and correct as necessary.

If the thermostatic expansion valve does not react to temperature rise calibration, it is probably malfunctioning and must be replaced. Valve replacement must be performed by an Authorised Service Centre.

7.8 Evaporators

Check the heat exchanger water side for cleanliness at regular intervals. This may be accomplished by checking water side pressure drop (refer to section 9) or simply by checking the fluid temperatures at heat exchanger inlet and outlet and comparing them with evaporation temperatures.

For effective heat exchange, the water outlet temperature and the saturated evaporation temperature should differ by 5 to 7°C. A larger difference indicates that the heat exchanger is operating inefficiently, and is thus soiled.

If soiled, the heat exchanger must be chemically cleaned by Authorised service personnel.

For other types of service (special maintenance, heat exchanger replacement, etc.), contact an authorised Service Centre.

7.9 Condensers

Check the condenser water side for cleanliness at regular intervals. This may be accomplished by checking water side pressure drop (refer to Section 9).

Soiling of the condenser results in increased condensing pressure, which reduces efficiency and increases current consumption and may cause the high pressure switch to activate.

It is advisable to supply the condensers with antialgae and anti-lime treated water.

If soiled, the heat exchanger must be chemically cleaned by Authorised service personnel.

For other types of service (special maintenance, heat exchanger replacement, etc.), contact an Authorised Service Centre.

8 TROUBLE SHOOTING

The following table details possible unit faults, their probable cause and suggested remedies. For any other problems not immediately recognisable and/or for technical assistance, call an Authorised Service Centre.

Fult	Probable Cause	Remedy
Differential oil pressure switch cuts on, break circuit.	Defective differential pressure switch operation.	Check switch operation, replacing if necessary.
	Low oil level as a result of circuit leakage.	Determine location of leak and repair.
	Start up with cold oil.	Check oil heater operation.
	Compressor lube circuit malfunction.	Call an Authorised Service Centre.
Unit operates continuously, but without cooling.	Low refrigerant charge.	Top up charge.
	Drier/filter clogged.	Replace drier/filter.
	Loss of efficiency in one or both circuits.	Check compressors and replace if necessary.
Suction line freezes.	Temperature rise of thermostatic valve out of calibration.	Increase setting.
		Check charge.
Excessive noise	Vibrating pipework.	Secure pipework.
		Check pipework retainers.
	Thermostatic expansion valve hiss.	Top up charge.
		Check filter/drier, replacing if necessary.
	Noisy compressor.	Check condition of valves.
		Bearings have seized; replace compressor.
Check that compressor retaining nuts are tight.		
Low compressor oil level.	One or more gas or oil leaks in circuit.	Identify ad eliminate all leaks.
	Mechanical damage to compressor.	Call an Authorised Service Centre.
	Faulty crankcase oil heater.	Check electrical circuit and crankcase heater element operation, replacing any defective components.

Fault	Probable Cause	Remedy
One or both compressors not working	Power circuit interrupted.	Check power circuit for earth leakage and shorts. Check fuses.
	High pressure switch activation.	Reset pressure switch from panel and re-start unit. Identify and eliminate causes of pressure switch activation.
	Control circuit fuse blown.	Check control circuit for earth leakage and shorts. Change fuses.
	Loose terminal clamps.	Check clamp tightness.
	Power circuit thermal overload cut-out activation	Check operation of control and safety devices. Identify and eliminate cause of activation.
	Incorrect wiring	Check control and safety device wiring.
	Line voltage too low.	Check line voltage. If problem due to system, eliminate it. If problem is due to distribution network, inform the electricity supply company.
	Compressor motor short-circuited.	Check motor winding continuity.
	Compressor seizure.	Replace compressor.
Low pressure switch cuts in, braking circuit.	Gas leakage.	Identify and eliminate leakage.
	Insufficient charge.	Top up charge.
	Pressure switch failure.	Replace pressure switch.
High pressure switch cuts in, braking circuit.	High pressure switch malfunction.	Check switch operation, replacing if necessary.
	Delivery valve partially closed.	Open valve, replacing if necessary.
	Non-condensables in circuit.	Purge circuit.
	Condenser water circuit dirty.	Clean and descale if necessary.
Liquid line too hot.	Insufficient charge.	Identify and eliminate causes of charge loss and top up charge.
	Condenser water circuit dirty.	Clean and descale if necessary.
Liquid line freezes.	Liquid line valve partially closed.	Check that all valves are open.
	Receiver/drier clogged.	Replace cartridge.

9 TECHNICAL DATA

9.1 Pressure Drop Graphs

RWC and RWR at R22 Models 60 to 150 - Evaporators

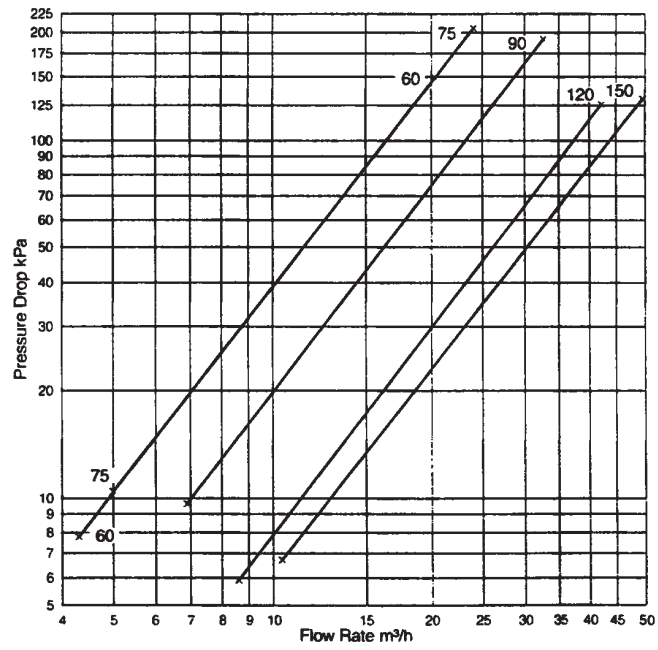

Note: Total unit flow rate is shown

RWC and RWR at R407C Models 60 to 150 - Evaporators

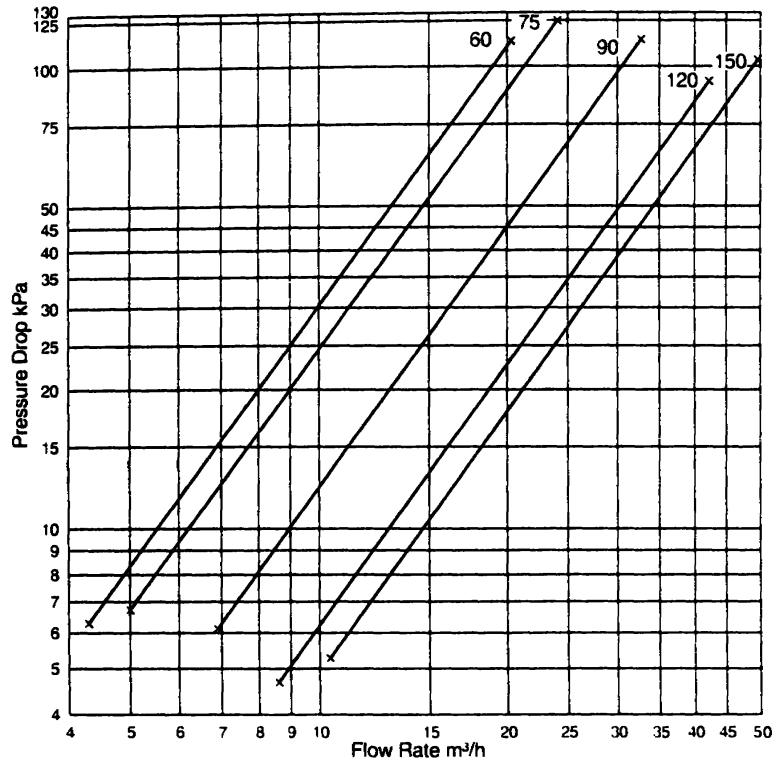

Note: Total unit flow rate is shown.

RWC and RWR (R22 and R407C) Models 170 to 280 - Evaporator

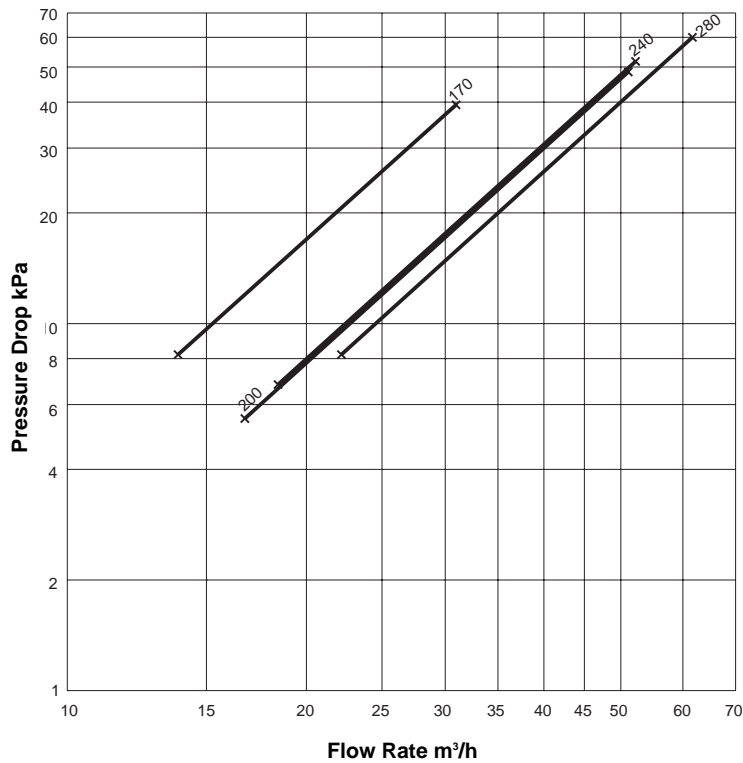

Note: Total unit flow rate is shown.

RWC (at R22 and R407C) Models 60 to 150 - Condensers

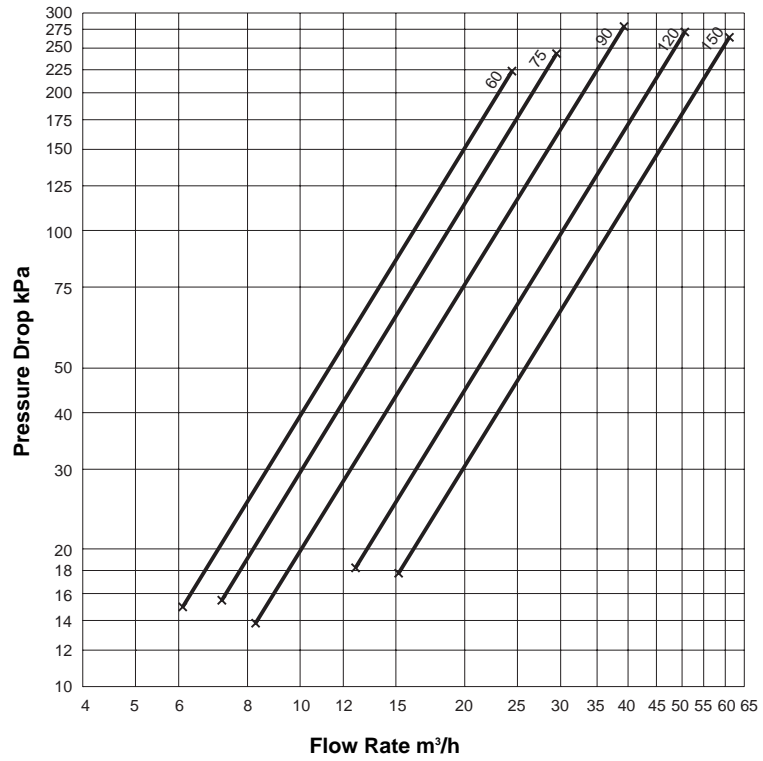

Note: Total unit flow rate is shown.

RWC (at R22 and R407C) Models 170 to 280 - Condensers

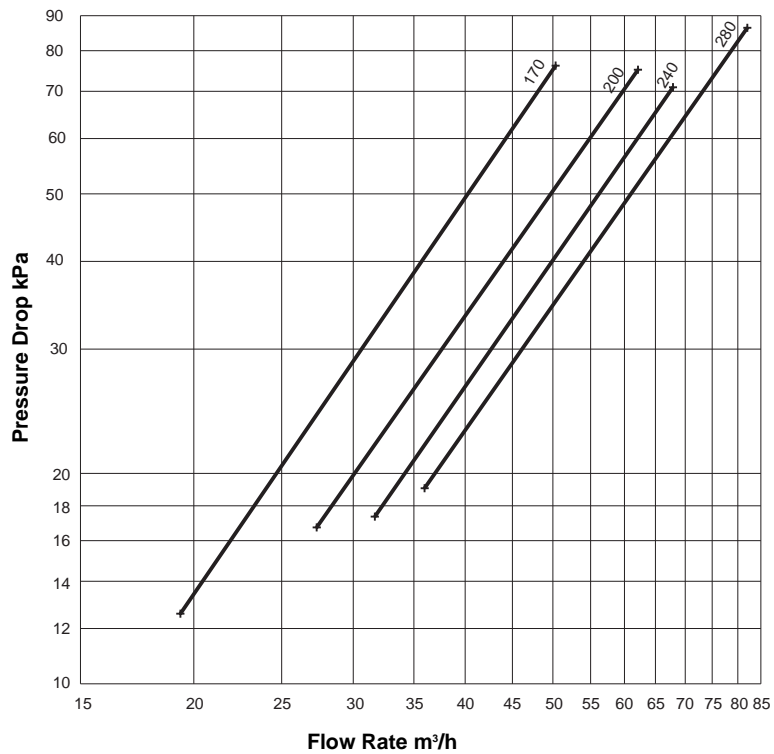

Note: Total unit flow rate is shown.

9.2 Safety Switch Settings

RWC / RWR		60	75	90	120	150	170	200	240	280
Low Pressure Switch	bar	0,5								
High Pressure Switch	bar	28				28				
TüV High Pressure Switch	bar	25								
Anti Freezing Thermostat	°C	4								
Safety Valve (Ispesl)	bar	24								
Evaporator Water Differential Pressure Switch	mbar	105								

9.3 Operational Limits

RWC / RWR				60		75		90		120		150	
				Min.	Max.	Min.	Max.	Min.	Max.	Min.	Max.	Min.	Max.
Chilled Liquid	Evaporator Water outlet temperature	Water outlet	°C	5 to 15 (R22) - 6 to 15 (R407C)									
		Brine outlet	°C	-10 to 15 (R22) - -5 to 15 (R407C)									
		Temp. Spread	°C	3,5 to 8									
	Flow rate ⁽¹⁾	m ³ /h	4.3	20.3	5.0	24.0	6.9	32.7	8.6	42.1	10.4	50.4	
	Pressure drop ⁽¹⁾	R407C	kPa	6.3	112.9	6.7	125.1	6.1	113.8	4.7	93.0	5.3	103.4
R22		kPa	7.8	149.5	10.4	205.6	9.6	191.6	5.9	125.6	6.7	130.6	
	Max. working pressure	bar	10										
Cooling Liquid	Liquid outlet temperature	Water outlet	°C	25 to 50 (R22) - 30 to 50 (R407C)									
		Temp. spread	K	3 to 8									
	Flow rate ⁽¹⁾ (Min.)	m ³ /h	6.1	24.4	7.2	29.5	8.3	39.2	12.6	50.7	15.2	61.2	
	Pressure drop ⁽¹⁾	kPa	15.2	212.2	15.7	230.7	13.8	271.4	18.2	265.0	17.7	258.2	
	Max working pressure ⁽¹⁾	bar	10										
Power supply voltage 400 V, 3 Ø, 50 Hz (nominal)			V	360 to 440									
Recommended system water volume ⁽²⁾			l	730		860		1050		1550		1750	

Note: 1 Total unit flow rate and pressure drop are given
 2 Table shows minimum water / brine volume of system

RWC / RWR				170		200		240		280	
				Min.	Max.	Min.	Max.	Min.	Max.	Min.	Max.
Chilled Liquid	Evaporator Water outlet temperature	Water outlet	°C	5 to 12 (R22) - 6 to 12 (R407C)							
		Brine outlet	°C	-10 to 12 (R22) - -5 to 12 (R407C)							
		Temp. Spread	°C	3,5 to 8							
	Flow rate ⁽¹⁾	m ³ /h	13.7	31.0	23.0	51.1	23.4	52.6	27.4	61.6	
	Pressure drop ⁽¹⁾	kPa	8.1	39.4	10.1	46.9	10.8	51.3	12.4	60.4	
	Max. working pressure ⁽¹⁾	bar	10								
Cooling Liquid ⁽²⁾	Liquid outlet temperature	Water outlet	°C	25 to 50							
		Temp. spread	K	3 to 8							
	Flow rate ⁽¹⁾ (Min.)	m ³ /h	21.6	50.4	27.4	62.0	31.6	67.8	36.0	82.0	
	Pressure drop ⁽¹⁾	kPa	15.0	77.7	16.9	80.2	17.7	74.6	18.6	89.6	
	Max working pressure ⁽¹⁾	bar	10								
Power supply voltage 400 V, 3 Ø, 50 Hz (nominal)			V	360 to 440							
Recommended system water volume ⁽²⁾			l	960		1160		1280		1640	

Nota: 1 Total unit flow rate and pressure drop are given
 2 Total unit flow rate and pressure drop are given
 3 Table shows minimum water / brine volume of system

9.4 Physical Data

RWC / RWR			60	75	90	120	150
Refrigerant Circuits			2	2	2	2	2
Refrigerant Charge per circuit	R22	kg	2	2.2	3	4	4.5
	R407C	kg	2.3	2.6	4	4.2	4.7
Compressor	Type		Hermetic Reciprocating				
	Number		2	2	2	2	2
	Oil charge per compressor	l	2.9	3.1	6.6	6.6	6.6
	No. of loading stage	%	100-50	100-50	100-50	100-50	100-50
Evaporator	Number		2	2	2	2	2
	Type		Plate Heat Exchanger				
	Water volume per evaporator	l	2.85	3.32	3.76	5.64	6.58
Water cooled Condenser	Number		2	2	2	2	2
	Type		Plate Heat Exchanger				
	Water volume per condenser	l	2.37	2.85	2.82	3.76	4.7
RWC Weight	Shipping R407C (R22)	kg	440 (435)	450 (440)	587 (577)	600 (587)	621 (607)
	Operating R407C (R22)	kg	430 (425)	440 (430)	577 (567)	590 (577)	611 (597)
RWR Weight	Shipping R407C (R22)	kg	412 (407)	422 (412)	559 (549)	572 (559)	593 (579)
	Operating R407C (R22)	kg	402 (397)	412 (402)	549 (539)	562 (549)	583 (569)
Dimensions	Length	mm	1210	1210	1210	1210	1210
	Width	mm	758	758	758	758	758
	Height	mm	1060	1060	1060	1060	1060

RWC / RWR			170	200	240	280
Refrigerant Circuits			2	2	2	2
Refrigerant Charge per circuit	R22	kg	9.1	9.5	10.0	13.8
	R407C	kg	8.5	8.6	9.9	11.0
Compressor	Type		Hermetic Reciprocating			
	Number		4	4	4	4
	Oil charge per compressor	l	7	7	7	7
	No. of loading stages	%	100-75	100-75	100-75	100-75
			50-25	50-25	50-25	50-25
Evaporator	Number		1	1	1	1
	Type		S&T	S&T	S&T	S&T
	Water volume per evaporator	l	41.8	62.7	58.1	53.2
Water cooled Condenser	Number		2	2	2	2
	Type		S&T	S&T	S&T	S&T
	Water volume per condenser	l	6.1	7.2	8	9.4
RWC Weight	Shipping	kg	1117	1215	1251	1322
	Operating	kg	1062	1136	1177	1250
RWR Weight	Shipping	kg	974	1061	1091	1140
	Operating	kg	931	996	1033	1049
Dimensions	Length	mm	2200	2200	2200	2200
	Width	mm	800	800	800	800
	Height	mm	1600	1600	1600	1600

9.5 Unit Electrical Data

Model		RWC / RWR				
		60	75	90	120	150
Current Input (A)	Nom. Cond.	30	36	45	64	76
	Max. Cond.	34	43	52	73	88
Power Input (KW)	Nom. Cond.	16	19	23	33	41
	Max. Cond.	20	23	29	41	51

Nominal conditions at 7°C chilled water outlet temperature, 35°C condenser outlet temperature (RWC)
 Maximum conditions at 12°C chilled water outlet temperature, 50°C condenser outlet temperature (RWC)
 Nominal conditions at 7°C chilled water outlet temperature, 40°C condenser outlet temperature (RWR)
 Maximum conditions at 12°C chilled water outlet temperature, 55°C condenser outlet temperature (RWR)

Model		RWC / RWR			
		170	200	240	280
Current Input (A)	Nom. Cond.	92	104	128	152
	Max. Cond.	108	124	152	184
	Max. start	206	243	304	353
Power Input (KW)	Nom. Cond.	49	58	66	81
	Max. Cond.	63	75	85	105

Nominal conditions at 7°C chilled water outlet temperature, 35°C condenser outlet temperature (RWC)
 Maximum conditions at 12°C chilled water outlet temperature, 50°C condenser outlet temperature (RWC)
 Nominal conditions at 7°C chilled water outlet temperature, 40°C condenser outlet temperature (RWR)
 Maximum conditions at 12°C chilled water outlet temperature, 55°C condenser outlet temperature (RWR)

9.6 Compressor Electrical Data

Model	System	Voltage (V)	Power input at Nom. Cond. per Comp. (kW)	Power Input at Max. Cond. per Comp. (kW)	Current at Nom. Cond. per Comp. (A)	Max. Current per Comp. (A)	DOL Starting Current (A) LRA	Max Fuse Size (A)	Line Conductor Cross Section mm ²
60	1+2	400	8	10	15	17	80	63	25
75	1+2	400	9	12	18	22	125	63	25
90	1+2	400	12	15	23	27	125	60	25
120	1+2	400	17	21	32	38	190	100	35
150	1+2	400	21	27	38	46	200	120	35

Nominal conditions at 7°C chilled water outlet temperature, 35°C condenser outlet temperature
 Maximum conditions at 12°C chilled water outlet temperature, 50°C condenser outlet temperature

Model	System	Voltage (V)	Power input at Nom. Cond. per Comp. (kW)	Power Input at Max. Cond. per Comp. (kW)	Current at Nom. Cond. per Comp. (A)	Max. Current per Comp. (A)	DOL Starting Current (A) LRA	Max Fuse Size (A)	Line Conductor Cross Section mm ²
170	1+2+3+4	400	12	15	23	27	125	120	50
200	1+2+3+4	400	14	18	26	31	150	160	70
240	1+2+3+4	400	17	21	32	38	180	200	95
280	1+2+3+4	400	21	27	38	46	200	250	120

Nominal conditions at 7°C chilled water outlet temperature, 35°C condenser outlet temperature
 Maximum conditions at 12°C chilled water outlet temperature, 50°C condenser outlet temperature

9.7 Sound Power Levels

RWC Model	Standard Units		Units with Acoustic Kit	
	R22	R407C	R22	R407C
	Sound Power dB(A)	Sound Power dB(A)	Sound Power dB(A)	Sound Power dB(A)
60	67	70	-	-
75	68	71	-	-
90	68	71	-	-
120	69	72	-	-
150	70	73	-	-
170	90	97	74	81
200	90	97	74	81
240	91	98	75	82
280	92	99	76	83

Tolerance +/- 2 dB(A)
Acoustic Kit supplied as standard on Models 60 to 150

9.8 Space Requirements

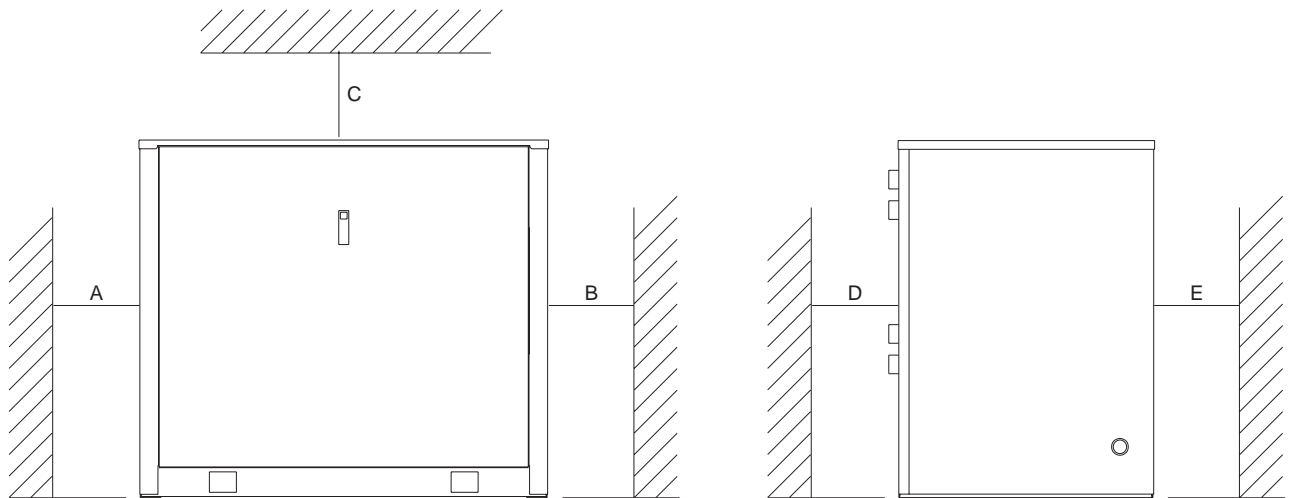

Model	Distance (mm)				
RWC	A	B	C	D	E
60 to 150	600	600	600	1000	1000
170 to 280	2200	800	1000	1000	1500

9.9 Dimensions

RWC/ RWR Models 60 to 150

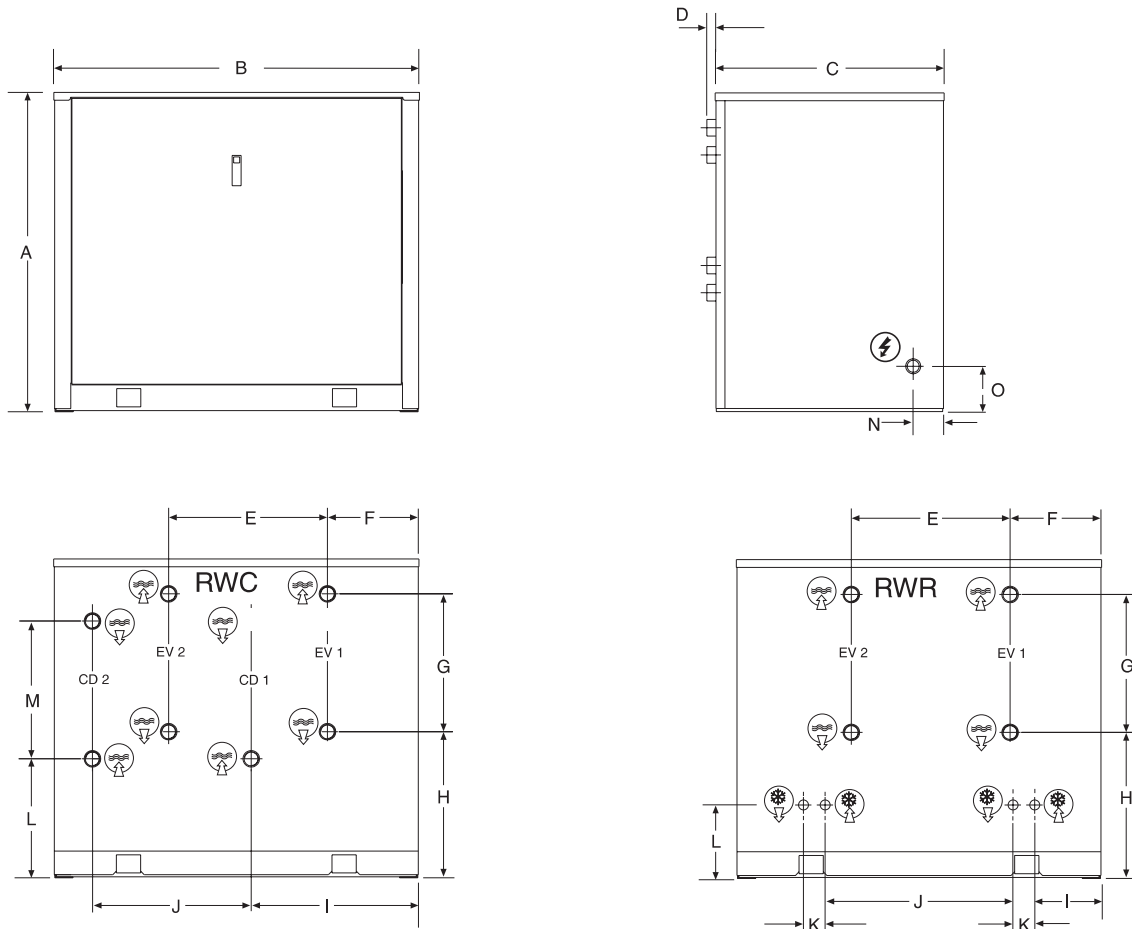

Note:
EV = Evaporator
CD = Condenser

RWC															Evaporator Pipe Connections	Condenser Pipe Connections	
Model	A	B	C	D	E	F	G	H	I	J	K	L	M	N	O		
60	1060	1210	758	20	500	278	479	500	500	500	-	410	479	100	150	ISO-G 1"	ISO-G 1"
75	1060	1210	758	20	500	278	479	500	500	500	-	410	479	100	150	ISO-G 1"	ISO-G 1"
90	1060	1210	758	26	555	286	456	510	538	555	-	420	456	100	150	ISO-G 1 1/2"	ISO-G 1 1/2"
120	1060	1210	758	26	555	286	456	510	538	555	-	420	456	100	150	ISO-G 1 1/2"	ISO-G 1 1/2"
150	1060	1210	758	26	555	286	456	510	538	555	-	420	456	100	150	ISO-G 1 1/2"	ISO-G 1 1/2"

RWR															Evaporator Pipe Connections	Refrigerant Inlet Connections	Refrigerant Outlet Connections	
Model	A	B	C	D	E	F	G	H	I	J	K	L	M	N	O			
60	1060	1210	758	20	500	278	479	500	295	430	70	390	-	100	150	ISO-G 1"	5/8"	7/8"
75	1060	1210	758	20	500	278	479	500	295	430	70	390	-	100	150	ISO-G 1"	5/8"	7/8"
90	1060	1210	758	26	555	286	456	510	225	485	70	390	-	100	150	ISO-G 1 1/2"	7/8"	1 1/8"
120	1060	1210	758	26	555	286	456	510	225	485	70	390	-	100	150	ISO-G 1 1/2"	7/8"	1 1/8"
150	1060	1210	758	26	555	286	456	510	225	485	70	390	-	100	150	ISO-G 1 1/2"	7/8"	1 1/8"

RWC Models 170 to 280

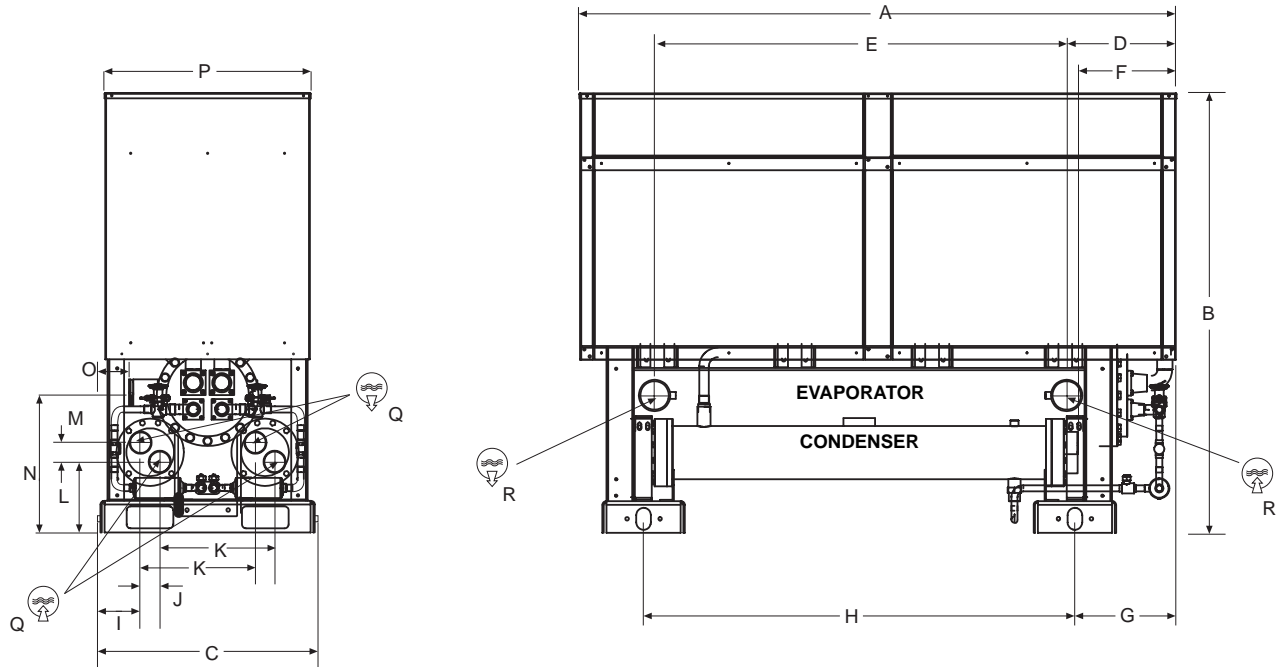

RWC																		
Model	A	B	C	D	E	F	G	H	I	J	K	L	M	N	O	P	Q	R
170	2200	1600	800	398	1500	358	368	1570	160	60	418	175	60	500	141	760	2"	3"
200	2200	1600	800	398	1500	358	368	1570	160	60	418	175	60	500	114	760	2"	4"
240	2200	1600	800	398	1500	358	368	1570	160	60	418	175	60	500	114	760	2"	4"
280	2200	1600	800	398	1500	358	368	1570	156	70	418	257	70	500	114	760	2 1/2"	4"

Dimensioni in mm unless stated

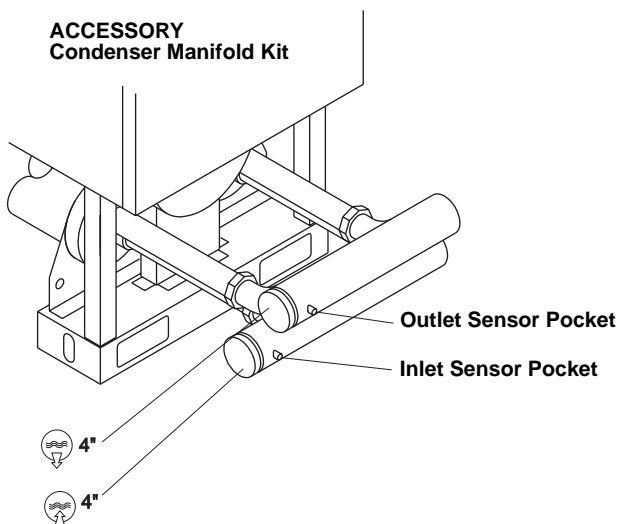

RWR Models 170 to 280

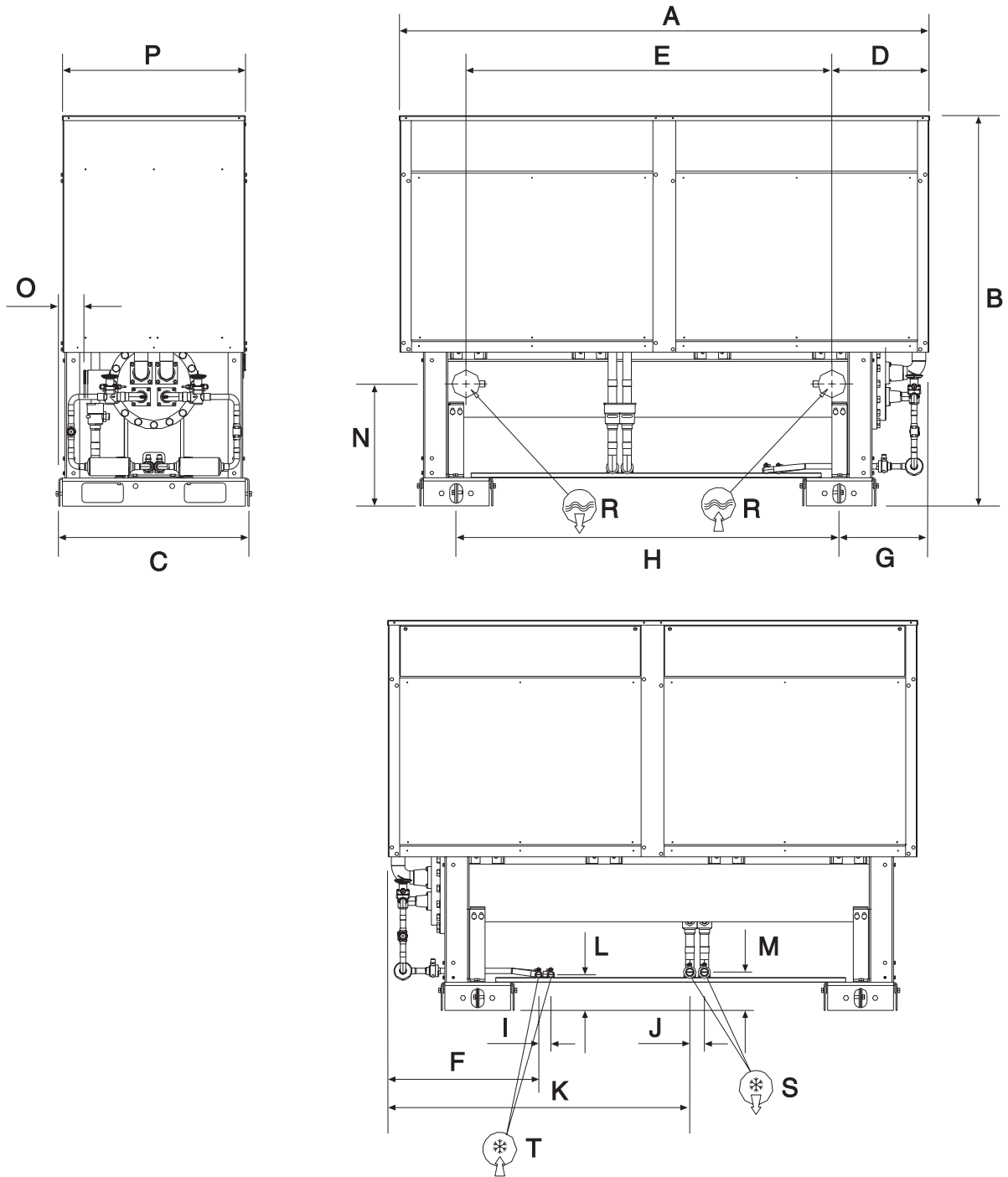

RWR																			
Model	A	B	C	D	E	F	G	H	I	J	K	L	M	N	O	P	R	S	T
170	2200	1600	800	398	1500	618	368	1570	50	60	1237	147	157	500	114	760	3"	1" 1/8"	7/8"
200	2200	1600	800	398	1500	618	368	1570	50	60	1237	147	157	500	114	760	4"	1" 1/8"	7/8"
240	2200	1600	800	398	1500	618	368	1570	50	60	1237	147	157	500	114	760	4"	1" 3/8"	7/8"
280	2200	1600	800	398	1500	618	368	1570	50	60	1237	147	157	500	114	760	4"	1" 3/8"	7/8"

Dimensioni in mm unless stated

9.10 Process and Instrumentation Diagrams

RWC Models 60 to 150

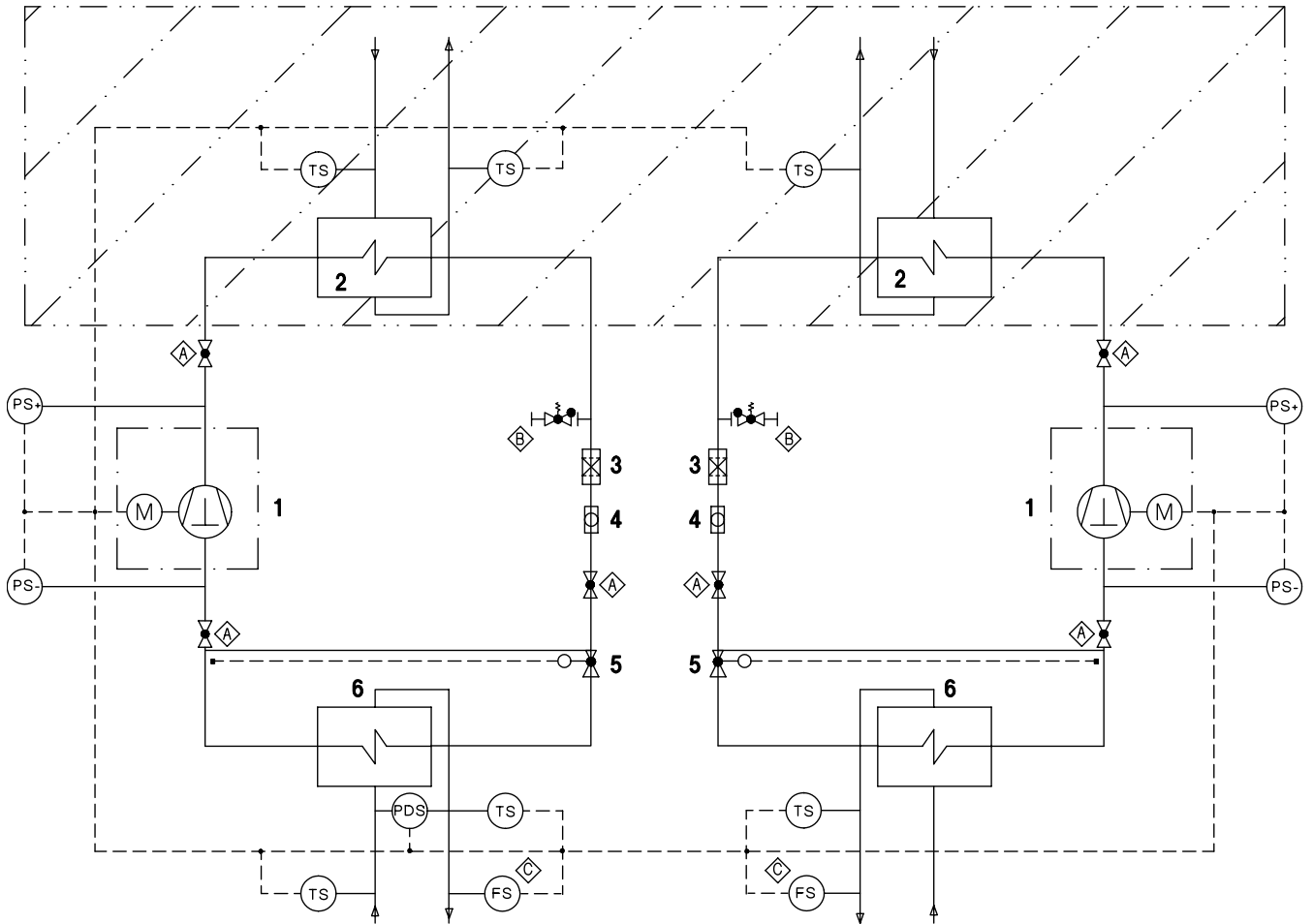

Code letters for Measure-, Switch- and Control					
Value (Pos. 1)	Add to Position 1		Function (Pos. 2)		
Pressure	P	Difference	D	Indicator	I
Temperature	T	Proportion	P	Recorder	R
Level	L	Relation	R	Counter	Q
Flow Rate	F			Controller	C
Density	D			Alarm	A
Humidity	M			Signal	S
Elect. Conductivity	S			Interlock	B
Velocity	C			Maximum	+
Viscosity	V			Minimum	-
Weight	W			Max.Min.	O
Concentration	K			Test Point	X
Safety Valve	Y			or Unit	
				Emergency	Z
n. DIN 19227					
Local	Display Remotely	Display in Panel	Display on Microprocessor Remotely		

Components

- 1 Compressor
- 2 Condenser
- 3 Filter Drier
- 4 Sight Glass
- 5 Expansion Valve
- 6 Evaporator

Notes

- Shut Off Valves
- Schrader Valve
- Flow Switch supplied as Kit

10 SPARE PARTS

10.1 Recommended Spares

The table below lists the recommended spares for one unit for 2 years.

Component	Q.ty
HP Switch	1
LP Switch	1
Differential Water Pressure Switch (only for RWC 60-150)	1
Gas Filter	2
Thermostatic Valve	1
Auxiliary Relays	2
Compressor Fuses	6
Auxiliary Fuses	6
Compressor Contactor	1
Power Contactor	1

10.2 Recommended Compressor Oils

The table below lists the recommended oil type for each unit.

RWC/ RWR Model	R22		R407C	
	Oil Type	Brand	Oil Type	Brand
60	1501	Shrieve Zerol	300SZ	CAN 300
75	1501	Shrieve Zerol	300SZ	CAN 300
90	1501	Shrieve Zerol	300SZ	CAN 300
120	1501	Shrieve Zerol	300SZ	CAN 300
150	1501	Shrieve Zerol	300SZ	CAN 300
170	1501	Shrieve Zerol	300SZ	CAN 300
200	1501	Shrieve Zerol	300SZ	CAN 300
240	1501	Shrieve Zerol	300SZ	CAN 300
280	1501	Shrieve Zerol	300SZ	CAN 300

11 DE-COMMISSIONING, DISMANTLING AND DISPOSAL



Never release refrigerant to the atmosphere when emptying the refrigerating circuits. Suitable retrieval equipment must be used. If reclaimed refrigerant cannot be re-used. It must be returned to the manufacturer.



Never discard used compressor oil, as it contains refrigerant in solution. Return used oil to the oil manufacturer.

Unless otherwise indicated, the operations described below can be performed by any properly trained maintenance technician.

11.1 General

Isolate all sources of electrical supply to the unit including any control system supplies switched by the unit. Ensure that all points of isolation are secured in the 'OFF' position. The supply cables may then be disconnected and removed. For connection points refer to Section 4.

Remove all refrigerant from each system of the unit into a suitable container using a refrigerant reclaim or recovery unit. This refrigerant may then be re-used, if appropriate, or returned to the manufacturer for disposal. Under NO circumstances should refrigerant be vented to atmosphere. Drain the refrigerant oil from each system into a suitable container and dispose of according to local laws and regulations governing the disposal of oily wastes. Any spilt oil should be mopped up and similarly disposed of.

Isolate the unit heat exchanger(s) from all external water systems and drain the heat exchanger section(s) of the system. If no isolation valves are installed it may be necessary to drain the complete system(s).



If glycol or similar solutions have been used in the water system(s), or chemical additives are contained, the solution MUST be disposed of in a suitable and safe manner. Under NO circumstances should any system containing glycol or similar solutions be drained directly into domestic waste or natural water systems.

After draining, the water pipework can be disconnected and removed.

Packaged units can generally be removed in one piece after disconnection as above. Any fixing down bolts should be removed and then the unit should be lifted from position using the points provided and equipment of adequate lifting capacity.

Reference should be made to Section 4 for unit installation instructions, Section 9 for unit weights and Section 3 for handling.

Units which cannot be removed in one piece after disconnection as above, must be dismantled in position. special care should be taken regarding the weight and the handling of each component. Where possible units should be dismantled in the reverse order of installation.



Residual refrigerant oil and glycol or similar solutions may remain in some parts of the system. These should be mopped up and disposed of as described above.

It is important to ensure that whilst components are being removed the remaining parts are supported in a safe manner.



Only use lifting equipment of adequate capacity.

After removal from position the unit parts may be disposed of according to local laws and regulations.

Wesper[®]



*As part of our ongoing product improvement programme, our products are subject to change without prior notice. Non contractual photos.
Dans un souci d'amélioration constante, nos produits peuvent être modifiés sans préavis. Photos non contractuelles.*

Wesper S.A.

42 cours Jean Jaurès

17800 Pons

France

☎ : +33-5 46 92 33 33

☎ : +33-5 46 91 38 33 - +33-5 46 91 26 44 (Export Department)

www.wesper.com

