

WESPAK

4.05, 5.05 & 6.05



English

Français

Belt drive compact air handling units

Centrales compactes de traitement d'air à transmission par courroies

IOM WPKBD-N.1GBF/06.05

Part number / Code : **Q3NSTE864**

Date : **June 2005 / Juin 2005**

Supersedes / Annule et remplace : **None / Aucun**



1 - Introduction

The purpose of this manual is to provide the installation, start-up, operating and maintenance rules to the users of the compact air handling units.

It does not give a full description of all maintenance works assuring the long life and reliability of this type of equipment. Only the services of qualified personnel, member of a registered maintenance company, can guarantee a reliable and durable running of the machine.

2 - Safety Precaution

Before installing the unit, please read the following safety precautions carefully.

Warning

Installation, operation and maintenance must be performed by qualified personnels who are familiar with local codes and regulations and experienced with this type of equipment.

Warning

All field wiring must be installed in accordance with the national wiring regulations.

Warning

Ensure the rated voltage of the unit corresponds to the name plate before carrying out wiring according to the supplied wiring diagram.

Warning

The unit must be GROUNDED to prevent possible hazards due to insulation failures.

Warning

All wiring must not touch the heat source or any moving parts of fan motor.

Warning

Confirm the unit is switched OFF before installing or servicing the unit.

Caution

Handling of the unit must be done by using the systems designed to support its weight.

Caution

It is forbidden to undertake any work on electrical components of the unit before disconnecting the power supply.

Caution

It is forbidden to undertake any work on electrical components of the unit, if there is presence of water and humidity.

Caution

When undertaking water connection, make sure that any foreign matters will not be introduced into water piping.

The manufacturer warranty will not be applied, if all installation instructions stated in this manual have not been followed.

3 - Inspection and Storage

When the equipment is received, all items must be carefully checked against the bill of lading to be sure all crates and cartons have been received.

The units are shipped on pallet. Inspect all units for visible or concealed damages.

In case of deterioration, formulate the precise reserves on the transport document and send immediately a registered letter to the forwarder, mentioning clearly the occurred damages and a copy of the letter to the manufacturer or its representative.

Do not stand or transport the unit on its end. Temporary storage must be indoor, completely sheltered from rain, snow, etc.

Change in the weather (high and low temperatures) should not damage the unit. Excessively high temperature (60 °C or more) may deteriorate certain plastic materials and cause permanent damages. In addition, some electric components and electronic boards may not operate correctly.

4 - Technical features

4.1 - Operating limits

| | | |
|-----------------------------|------------------------------|--------|
| Water piping system | Maximum operating pressure | 10 bar |
| | Minimum entering temperature | +4 °C |
| | Maximum entering temperature | +90 °C |
| Room air temperature | Minimum temperature | 5 °C |
| | Maximum temperature | 32 °C |
| Supply voltage | 400 V ± 10% / 3 ph / 50 Hz | |

4.2 - Physical data

| MODELS | | 4.05 | 5.05 | 6.05 | | |
|---|---|-------------|--------------|-------------|------|------|
| Air flow range | m ³ /h | 4000 - 6000 | 5500 - 7500 | 7000 - 9000 | | |
| Nominal air flow | m ³ /h | 5000 | 6500 | 8000 | | |
| Fan static pressure | Pa | 400 | 400 | 400 | | |
| Nominal cooling capacity (tot. / sens.) (1) | kW | 25.9 / 19.6 | 36.0 / 26.5 | 43.2 / 32.0 | | |
| Chilled water flow | l/h | 4441 | 6172 | 7409 | | |
| Nominal heating capacity (2) | kW | 21.3 | 29.9 | 35.8 | | |
| Hot water flow | l/h | 1223 | 1716 | 2056 | | |
| FAN | | | | | | |
| Type | Double wheel centrifugal | | | | | |
| Model | DA 9/9 N2T | DA 9/9 N2T | DA 10/10 N2T | | | |
| Drive | Adjustable pulley - Belt | | | | | |
| MOTOR | | | | | | |
| Type | IP55 - PTO - Class F - 400 V / 3 Ph / 50 Hz | | | | | |
| Power | kW | 1.5 | 2.2 | 2.2 | 3.0 | 3.0 |
| Current | A | 3.45 | 4.8 | 4.8 | 6.48 | 6.48 |
| Rotational speed | rpm | 1420 | 1430 | 1430 | 1430 | 1430 |

4 - Technical Features (continued)

4.2 - Physical data (cont'd)

| MODELS | | 4.05 | | 5.05 | | 6.05 | |
|----------------------------------|--------|--|------|-------------------|------|-------------------|------|
| COOLING COILS | | | | | | | |
| Type | | Copper tubes - Aluminium fins - 2.1 mm spacing | | | | | |
| Finned length | mm | 1360 | | 1800 | | 1800 | |
| Number of tubes per row | | 15 | | 15 | | 17 | |
| Number of rows | | 4 | 6 | 4 | 6 | 4 | 6 |
| Number of circuits | | 15 | 22 | 15 | 22 | 17 | 25 |
| Number of empty tubes | | 0 | 2 | 0 | 2 | 0 | 2 |
| Header diameter (inlet/outlet) | mm | 33 / 42 - 33 / 42 | | 33 / 42 - 33 / 42 | | 33 / 42 - 33 / 42 | |
| Condensate drain diameter | inch | 7/8" | | 7/8" | | 7/8" | |
| Water content | litres | 8.4 | 16.1 | 10.5 | 20.7 | 11.6 | 23.2 |
| HEATING COIL | | | | | | | |
| Type | | Copper tubes - Aluminium fins - 2.1 mm spacing | | | | | |
| Finned length | mm | 1360 | | 1800 | | 1800 | |
| Number of tubes per row | | 15 | | 15 | | 17 | |
| Number of rows | | 2 | | 2 | | 2 | |
| Number of circuits | | 15 | | 15 | | 17 | |
| Number of empty tubes | | 0 | | 0 | | 0 | |
| Header diameter (inlet/outlet) | mm | 33 / 42 - 33 / 42 | | 33 / 42 - 33 / 42 | | 33 / 42 - 33 / 42 | |
| Water content | litres | 5.2 | | 6.2 | | 6.8 | |
| ELECTRIC HEATER | | | | | | | |
| Heating element type | | à ailettes | | lisse | | lisse | |
| BE1 capacity | kW | 12 | | 24 | | 36 | |
| BE2 capacity | kW | 24 | | 36 | | 48 (1) | |
| BE3 capacity | kW | 36 (1) | | 48 (1) | | 60 (1) | |
| Supply voltage | | 400 V / 3 Ph / 50 Hz + Neutral + Earth | | | | | |
| AIR FILTERS | | | | | | | |
| Filter efficiency | | G2 | G4 | G2 | G4 | G2 | G4 |
| Media type | | Synthetic | | | | | |
| Length | mm | 480 | | 470 | | 470 | |
| Height | mm | 445 | | 445 | | 500 | |
| Thickness | mm | 10 | 50 | 10 | 50 | 10 | 50 |
| Quantity | | 3 | | 4 | | 4 | |
| DIMENSIONS AND WEIGHT (2) | | | | | | | |
| Length | mm | 1150 | | 1350 | | 1350 | |
| Width | mm | 1550 | | 1990 | | 1990 | |
| Height | mm | 485 | | 485 | | 540 | |
| Weight | kg | 180 | | 250 | | 280 | |

(1) To be imperatively installed in discharge electric heater casing.

(2) For double skin configuration : 50 mm thick panel filter + cooling coil + heating coil + fan.

5 - Dimensions

5.1 - Fixation dimensions

a) By threaded rods only

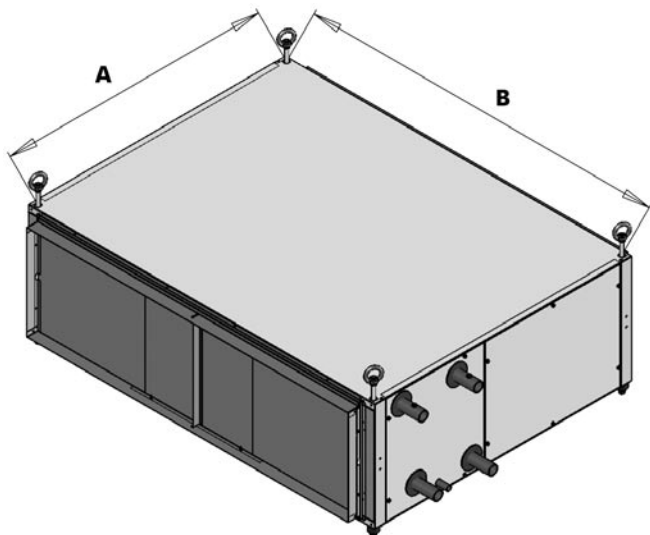

| Sizes | Dimensions (mm) | | | |
|-------|---|------|------------------------------------|------|
| | Fan only casing or electric heater casing | | Standard casing or silencer casing | |
| | A | B | A | B |
| 4.05 | 670 | 1498 | 1110 | 1498 |
| 5.05 | 870 | 1940 | 1310 | 1940 |
| 6.05 | 870 | 1940 | 1310 | 1940 |

b) By threaded rods and hanger rails

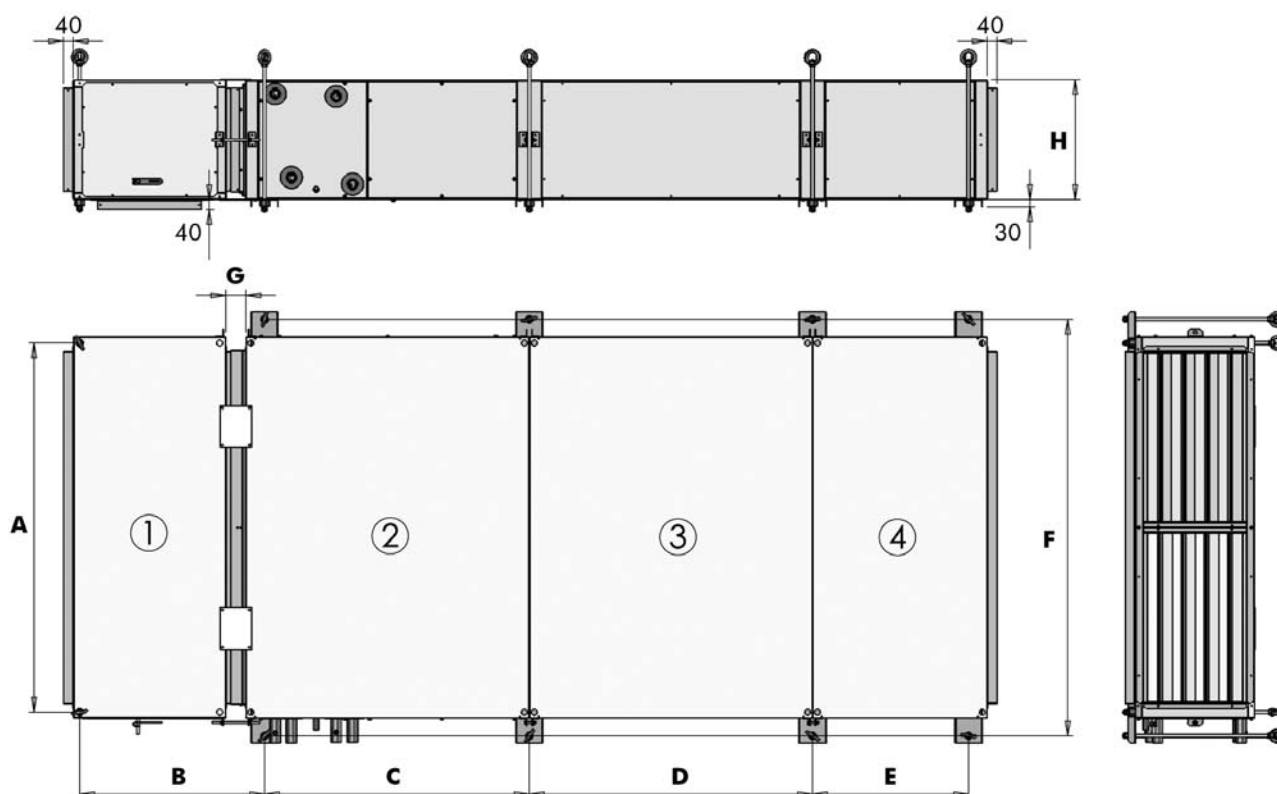

| Sizes | Dimensions (mm) | | | | | | | | |
|-------|-----------------|-----|------|------|-----|------|-----------|-----------|-----|
| | A | B | C | D | E | F | G | | H |
| | | | | | | | G2 filter | G4 filter | |
| 4.05 | 1498 | 750 | 1074 | 1150 | 633 | 1690 | 82 | 122 | 485 |
| 5.05 | 1940 | 750 | 1274 | 1350 | 833 | 2132 | 82 | 122 | 485 |
| 6.05 | 1940 | 852 | 1274 | 1350 | 833 | 2132 | 82 | 122 | 540 |

| | |
|---|------------------------|
| 1 | 2-way mixing box |
| 2 | Standard casing |
| 3 | Silencer casing |
| 4 | Electric heater casing |

5 - Dimensions (continued)

5.2 - Duct connections

Side view

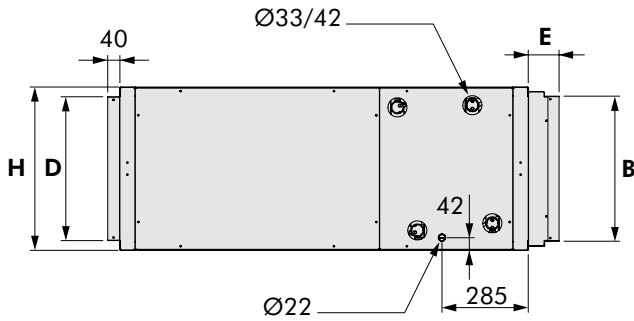

Rear view

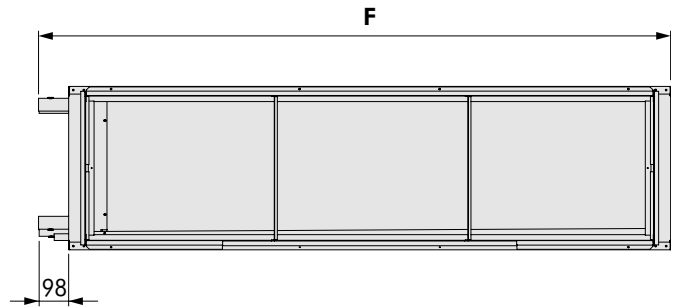

Front view

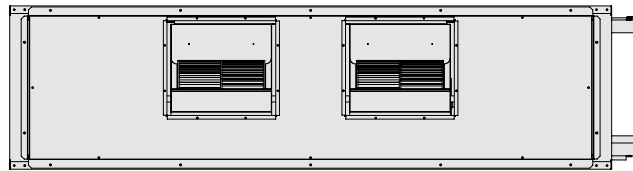

Top view

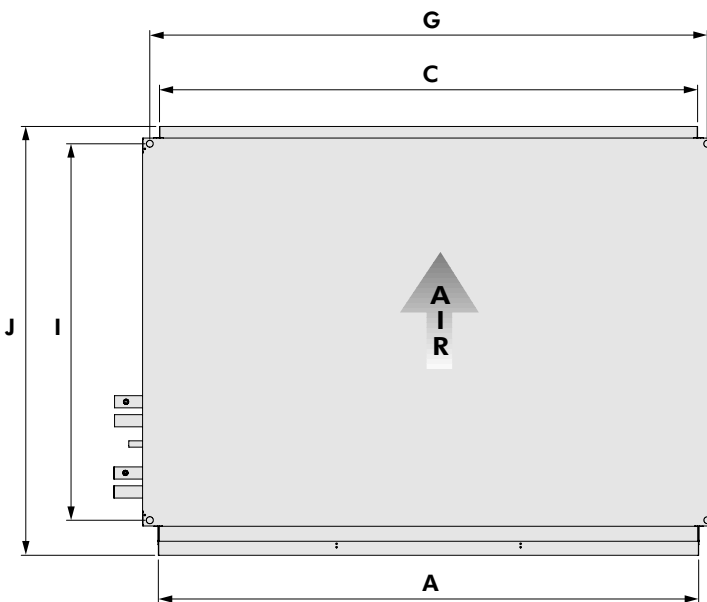

Bottom view

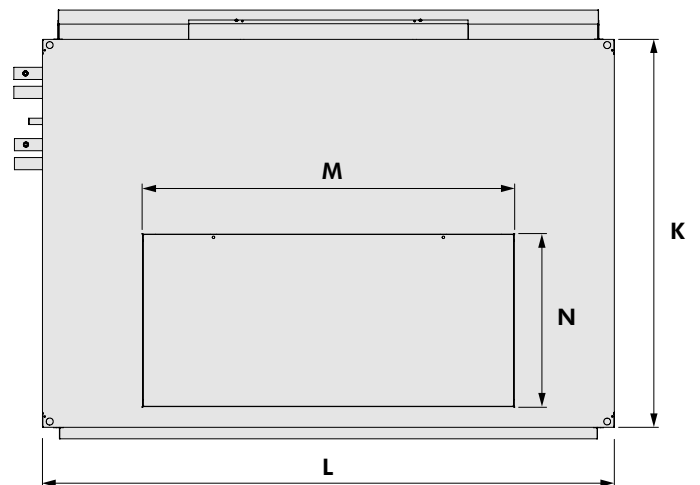

| Sizes | Dimensions (mm) | | | | | | | |
|-------|-----------------|-----|------|-----|-----------|-----------|------|------|
| | A | B | C | D | E | | F | G |
| | | | | | G2 filter | G4 filter | | |
| 4.05 | 1438 | 424 | 1430 | 420 | 62 | 102 | 1646 | 1498 |
| 5.05 | 1880 | 424 | 1872 | 420 | 62 | 102 | 2088 | 1940 |
| 6.05 | 1880 | 479 | 1872 | 475 | 62 | 102 | 2088 | 1940 |

| Sizes | Dimensions (mm) | | | | | | | |
|-------|-----------------|------|-----------|-----------|------|------|------|-----|
| | H | I | J | | K | L | M | N |
| | | | G2 filter | G4 filter | | | | |
| 4.05 | 485 | 1110 | 1252 | 1292 | 1150 | 1548 | 950 | 500 |
| 5.05 | 485 | 1310 | 1452 | 1492 | 1350 | 1990 | 1290 | 600 |
| 6.05 | 540 | 1310 | 1452 | 1492 | 1350 | 1990 | 1290 | 600 |

Remark : The dimensions of mixing box connection are identical to those of inlet duct collar connection (dimensions A & B).

5 - Dimensions (continued)

5.3 - Water connections

a) Cooling and heating configuration in the direction of air flow

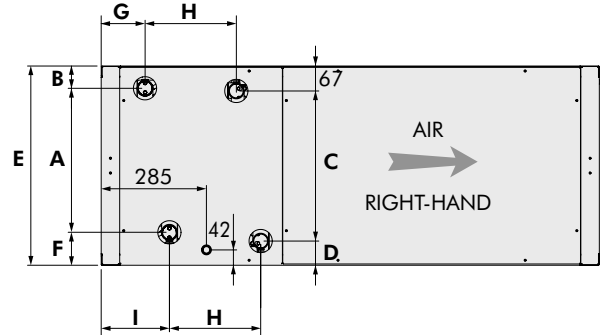
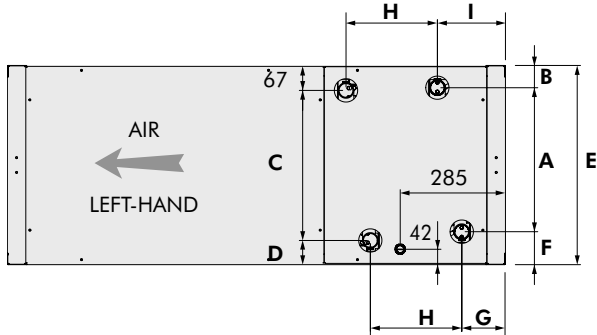

| Installation with 4-row cooling and 2-row heating coils | | | | | | | | | |
|---|-----|----|-----|----|-----|----|-----|-----|-----|
| Sizes | A | B | C | D | E | F | G | H | I |
| 4.05 | 339 | 57 | 356 | 62 | 485 | 89 | 119 | 247 | 185 |
| 5.05 | 339 | 57 | 356 | 62 | 485 | 89 | 119 | 247 | 185 |
| 6.05 | 390 | 57 | 407 | 66 | 540 | 89 | 119 | 247 | 185 |

| Installation with 6-row cooling and 2-row heating coils | | | | | | | | | |
|---|-----|----|-----|----|-----|----|-----|-----|-----|
| Sizes | A | B | C | D | E | F | G | H | I |
| 4.05 | 351 | 50 | 356 | 62 | 485 | 84 | 140 | 226 | 206 |
| 5.05 | 351 | 50 | 356 | 62 | 485 | 84 | 140 | 226 | 206 |
| 6.05 | 402 | 54 | 407 | 66 | 540 | 84 | 140 | 226 | 206 |

Dimensions are in mm.

b) Heating and cooling configuration in the direction of air flow

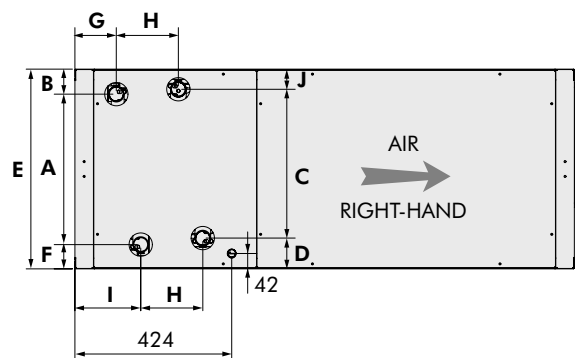
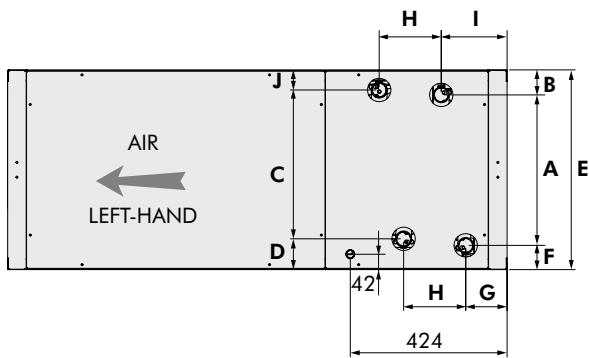

| Installation with 4-row cooling and 2-row heating coils | | | | | | | | | | |
|---|-----|----|-----|----|-----|----|-----|-----|-----|----|
| Sizes | A | B | C | D | E | F | G | H | I | J |
| 4.05 | 356 | 66 | 339 | 90 | 485 | 63 | 112 | 146 | 178 | 56 |
| 5.05 | 356 | 66 | 339 | 90 | 485 | 63 | 112 | 146 | 178 | 56 |
| 6.05 | 407 | 67 | 390 | 90 | 540 | 66 | 112 | 146 | 178 | 60 |

| Installation with 6-row cooling and 2-row heating coils | | | | | | | | | | |
|---|-----|----|-----|----|-----|----|-----|-----|-----|----|
| Sizes | A | B | C | D | E | F | G | H | I | J |
| 4.05 | 356 | 66 | 352 | 83 | 485 | 63 | 112 | 168 | 178 | 50 |
| 5.05 | 356 | 66 | 352 | 83 | 485 | 63 | 112 | 168 | 178 | 50 |
| 6.05 | 407 | 67 | 402 | 83 | 540 | 66 | 112 | 168 | 178 | 55 |

Dimensions are in mm.

6 - Installation

6.1 - Unit handling

Be careful to avoid rough handling on the unit. **Do not lift the unit by the condensate outlet or by the water connections.** Use a lifting truck to facilitate the unit installation.



Warning

Sharp edges and coil surfaces are a potential hazard. Avoid contact with them.

6.2 - Installation location

1. The units are designed to be installed above the false ceiling.
2. Install the unit in a position having sufficient strength to carry the weight of the unit.
3. Install the unit in a position where ducts can be connected to inlet and outlet sides of the unit.
4. Install the unit in a position from where condensate can be run to waste easily.
5. Check the distance between the upper slab and false ceiling to ensure the unit will suit the distance.
6. Ensure there is sufficient space around the unit to service it (see table hereafter for minimum clearances on service side of filters and fan-motor assembly access).



Warning

Do not install the unit in a machinery shop or kitchen where vapour from oil or its mist flows into the unit.

6.3 - Minimum service clearances

Leave sufficient space **on the bottom and the sides** of the unit to assure maintenance works or replacement of one or several internal components.

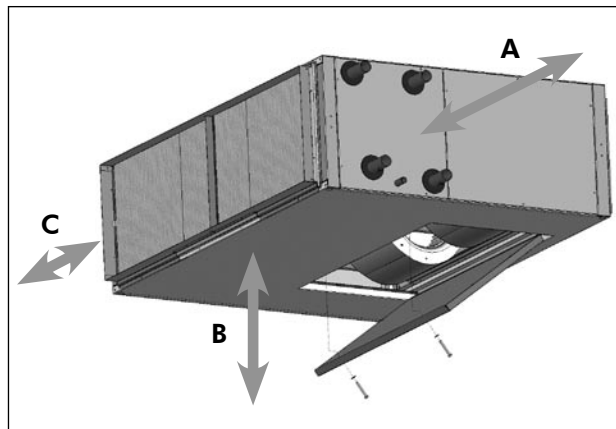

| Sizes | 4.05 | 5.05 | 6.05 |
|--------|------|------|------|
| A (mm) | 1600 | 2000 | 2000 |
| B (mm) | 500 | 500 | 600 |
| C (mm) | 500 | 500 | 500 |

6 - Installation (continued)

6.4 - Installation instructions

1. Prepare the fixing center distances at the ceiling for each casing (see section "Dimensions" for fixing center distances).
2. Fix the suspension kit (optional) composed of threaded rods only or threaded rods and hanger rails.
3. In the case that the suspension kit by threaded rods only is supplied, install the casing as indicated in the drawing below.

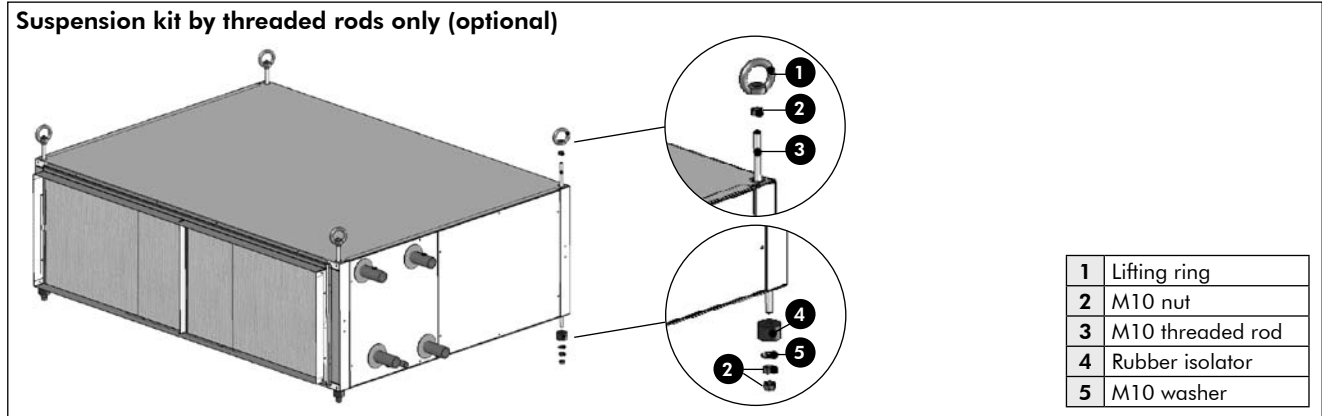

In the other case, fix the casing on the hanger rails with the aid of fixing screws, see drawing below.

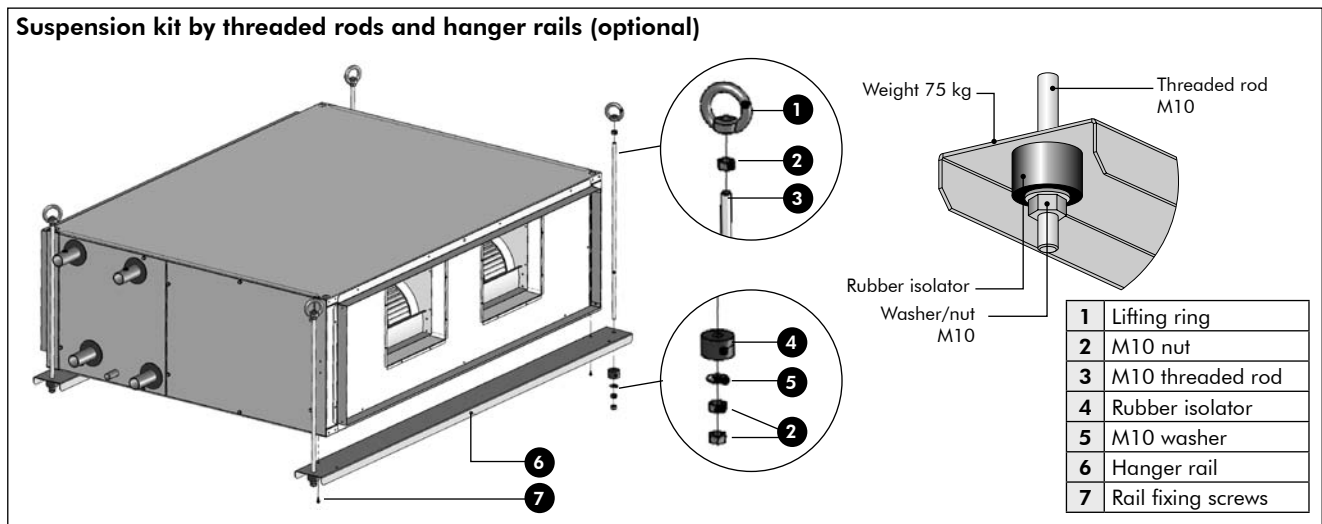

4. On the double casing units, assemble the two casing with the help of factory fitted assembling clamps and screws.

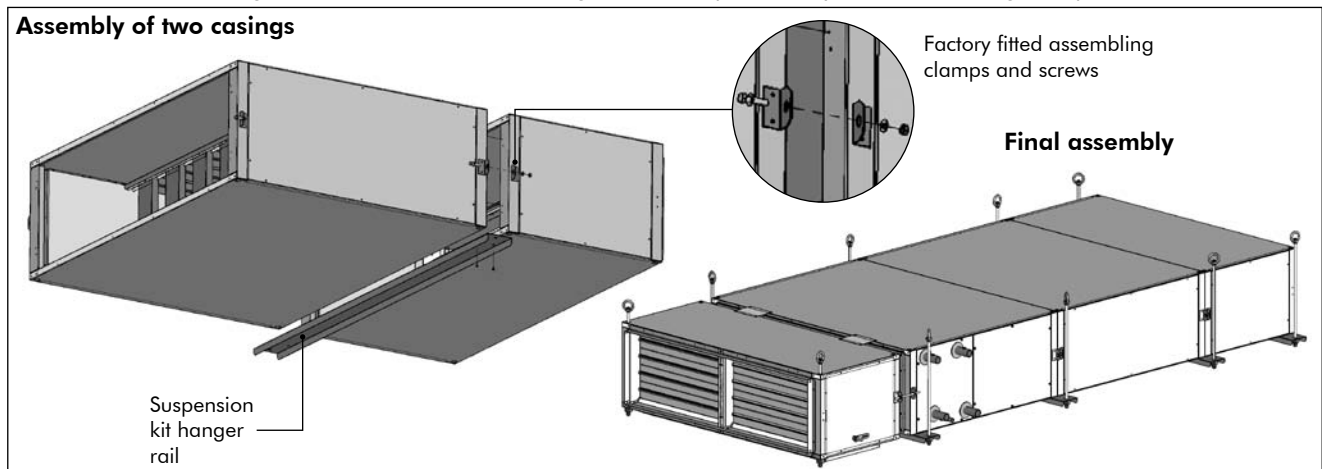

5. Secure the unit in its final position and **level it with a spirit level** to assure proper drainage and operation.
6. Unit must be mounted in such a way that water will flow toward drain connection.

7 - Water Connections

7.1 - Definition of the service side

The service side, the side where coil connections are located, is defined left-hand or right-hand, when observer looks at the unit from above in the direction of air.

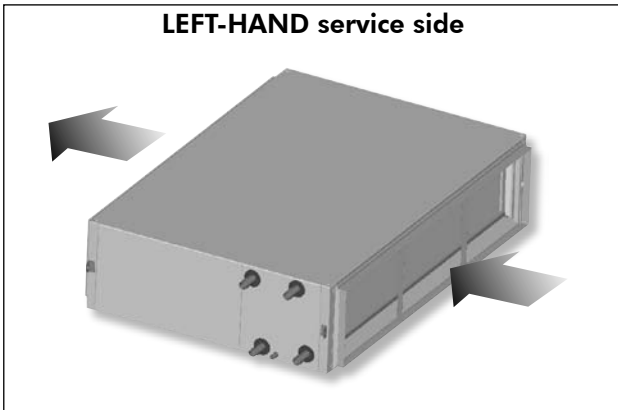
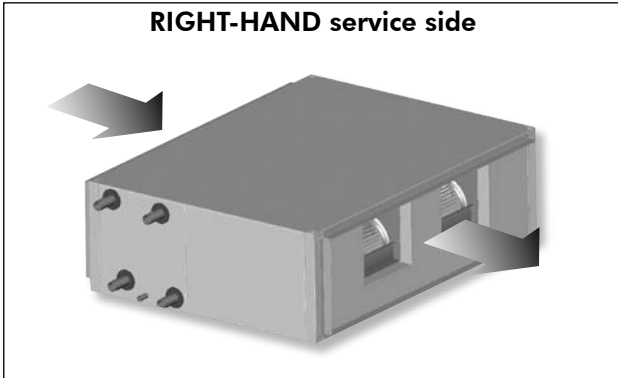

7.2 - Water coil connections

Each water coil is equipped with headers having $\text{Ø}33/42$ male threaded type connection on water supply and water return.

Air vent must be installed at highest point of the water piping.

To ensure an optimum heat transfer efficiency, connections of water supply and return should be arranged in such a way that a **counter flow configuration between air and water is obtained.**

Flexible hoses are recommended for coil connections. Tighten normally the water connections. Note that an excessive tightening can cause too strong material stresses at the time of significant temperature changes.

All water lines should be insulated to prevent sweating and heat loss.



Caution

If the units are not equipped with control valves, the air temperature must not exceed 50 °C.



Warning

To avoid any damage on coil, use two spanners to tighten the water pipe fittings on each header.

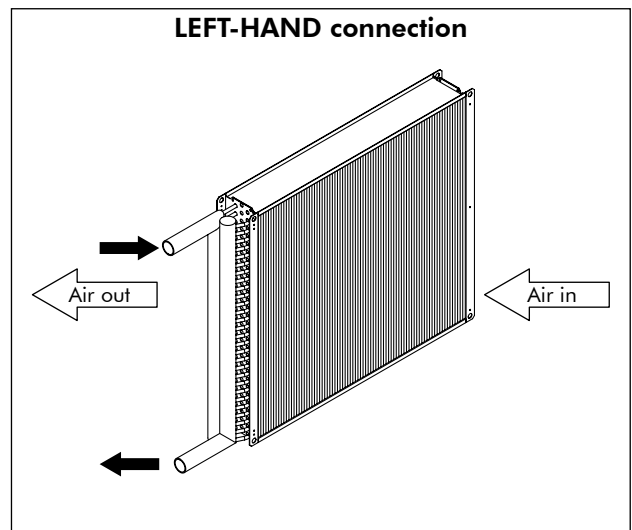
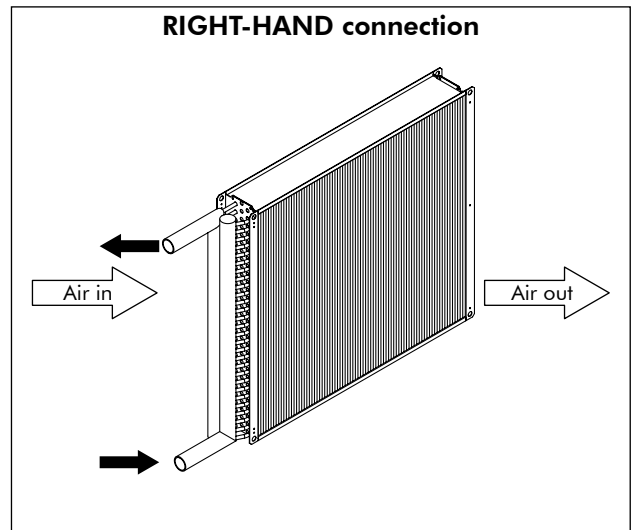

7 - Water Connections (continued)

7.3 - Condensate drain connection

The condensate drain pan is supplied with 7/8" OD copper tube outlet.

Ensure that water condensate will be properly drained out from the drain pan which must be connected to the main drain piping.

The drain line must be installed with a downward slope. Ensure water trap is available on drain piping.

On completion, the drain line should be insulated.

Caution

Check that there is no counter-slope which would prevent condensates from flowing.

Warning

All foreign material must be removed from the drain pan.

7.4 - Winterizing water coils

In winter, due to a general shutdown of the installation or a failure of outdoor air damper control, coil freeze-up may occur.

To avoid coil damage, it is recommended to drain completely the non used coils or to fill them with an anti-freeze solution.

The concentration of anti-freeze solution must be regularly and carefully checked before each winter season.

It is highly advised to place a heating coil before a cooling coil for an operation during winter season.

Caution

Carefully read instructions for mixing anti-freeze solution used. Some products will have a higher freezing point in its natural state than when mixed with water.

The freezing of coils is not the responsibility of the manufacturer.

Trap for condensate evacuation

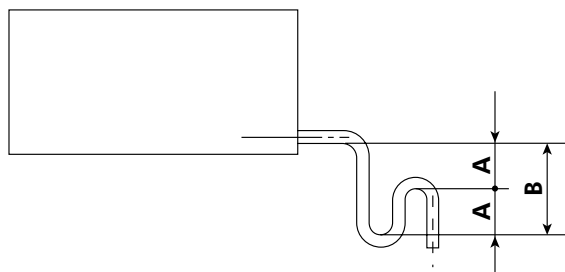

The height A must be equal to **2 times** the value of the negative pressure present in the condensate reception zone (example : negative pressure = 40 mm, height A = 80 mm, height B = 160 mm).

8 - Electrical connections

8.1 - Unit connection

Before undertaking any electrical connection, make sure that the fan motor is suitable for electrical power supply.

All wiring must be done in accordance with applicable electrical codes and regulations.

Earthing of unit is imperative.

The manufacturer or its representative will not be held responsible for accidents caused by incorrect or non-existing earthing.

The units are not supplied with electrical panel.

Wiring on the electric motors must be done at site. All motors are designed and produced in accordance with the standards in use.

The connection of these motors will be done according to the indications affixed on the nameplate and on the diagram located in the terminal box.

All motors are equipped, as standard, with a normally closed internal overload protection sensor. This safety device shall

be imperatively connected to the control circuit of the motor. The non-respect of this instruction will cancel compulsorily the warranty on the motor.

Power supply cables entering into the unit, must be run through cable glands mounted on unit panel.

All orifices for cable entry done on the panels must be sealed to prevent leakage.

8.2 - Electric heater

The factory mounted electric heater is fitted with a manual reset high temperature cut-out switch which de-energizes the heater in case of fan motor failure.

For electrical connection, refer to wiring diagram stuck on the unit.

⚠ Caution

The electric heater must never operate without the ventilation.

Single speed motors (1)

| Dual-voltage motors with Y / Δ connections | Skeleton diagrams | External connection diagrams | |
|--|-------------------|------------------------------|----------------|
| | | D.O.L. starting | Y / Δ starting |
| <ul style="list-style-type: none"> - Voltage : U - Connection : Δ (at lower marked voltage) - E.G. : 230 V / Δ | | | |
| <ul style="list-style-type: none"> - Voltage : U √3 - Connection : Y (at lower marked voltage) - E.G. : 400 V / Y | | | |

(1) Diagrams valid for :

- 3-phase 230 Δ / 400 Y V motors with power from 0.25 to 4.5 kW at 1500 rpm and from 0.25 to 5.5 kW at 3000 rpm,
- 3-phase 400 Δ V motors with power higher or equal to 5.5 kW at 1500 rpm, using Y / Δ starter.

9 - Preliminary Checks Before Start-up

When performing startup and service, thorough safety precautions should always be taken.

Only qualified individuals should perform these functions.

1. Check that the unit is completely and properly installed with ductwork connected.
2. Check that all construction debris are removed and filters are clean.
3. Check that the electrical work is complete and properly terminated.
4. Check that the electrical connections are tight and that the proper voltage is connected.
5. Check that all holes for cable entry are tightly sealed.
6. Check tightness of setscrews on motors, bearings and fans.
7. Check alignment of fan and motor pulleys and belt tension (see drawings below).
8. Check that coil and drain pan connections are properly done.
9. Leak test thermal system to insure that connections are tight.
10. Check that condensate drain is trapped.
11. Check that fans rotate freely.

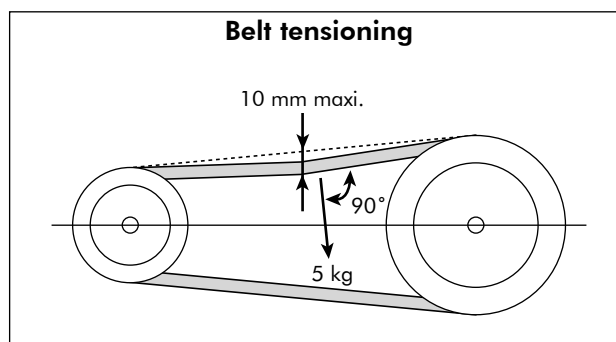
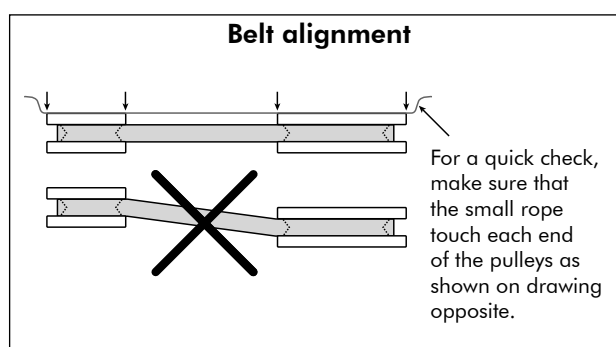

9 - Preliminary Checks Before Start-up (continued)

9.1 - Adjustable pulley adjustment

Mounting

1. The pulley must be mounted on the motor shaft with the aid of the set screws "A".
2. Be sure that both driving and driven pulleys are in alignment and that shafts are parallel (see paragraph "Belt alignment").
3. Securely tighten the set screw "A" on the keyway of the motor shaft.

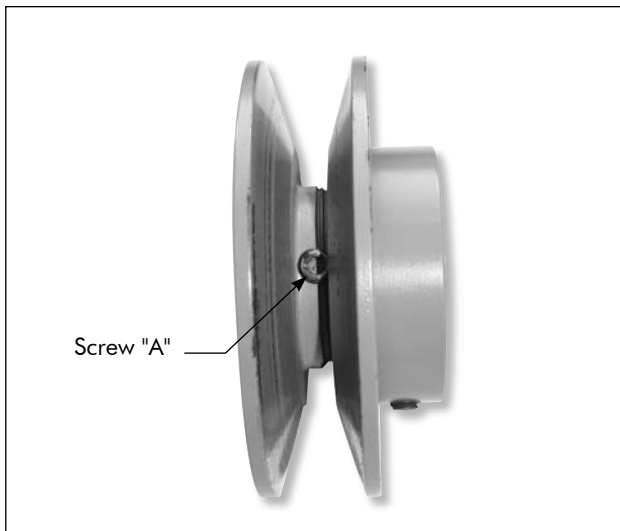

Adjusting

1. Loosen the set screw "B" located in the pulley moving sheave.
2. Adjust the sheave pitch diameter for a desired rotational speed by opening the moving sheave by half turns or full turns from the closed position.

$$\text{Fan rotational speed (rpm)} = \text{Motor rotational speed (rpm)} \times \frac{\text{Motor pulley diameter}}{\text{Fan pulley diameter}}$$

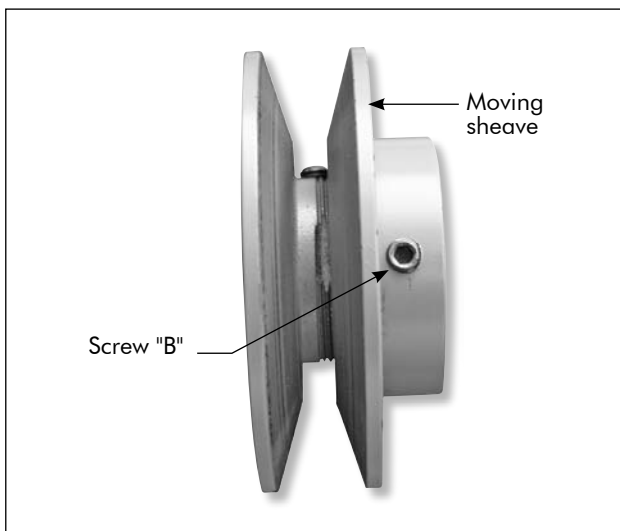

3. Securely tighten the set screw "B" on the flat surface of the pulley fixed sheave.
4. Put on the belt and adjust its tension. **Do not force the belt on the pulley sheaves** (see paragraph "Belt tensioning").
5. The future adjustments should be performed by loosening the belt tension and by increasing or decreasing the pulley pitch diameter by half turns or full turns as required. Re-adjust the belt tension before starting the motor.
6. Make certain that all parts are in place and that all set screws are tight before starting the motor. Check set screws and belt tension after a 24 hour operation.

Remark : The authorized maximum opening of the pulley is 3.5 turns from the completely closed position. If this maximum opening is not followed, there is a risk of early breaking of the belt.

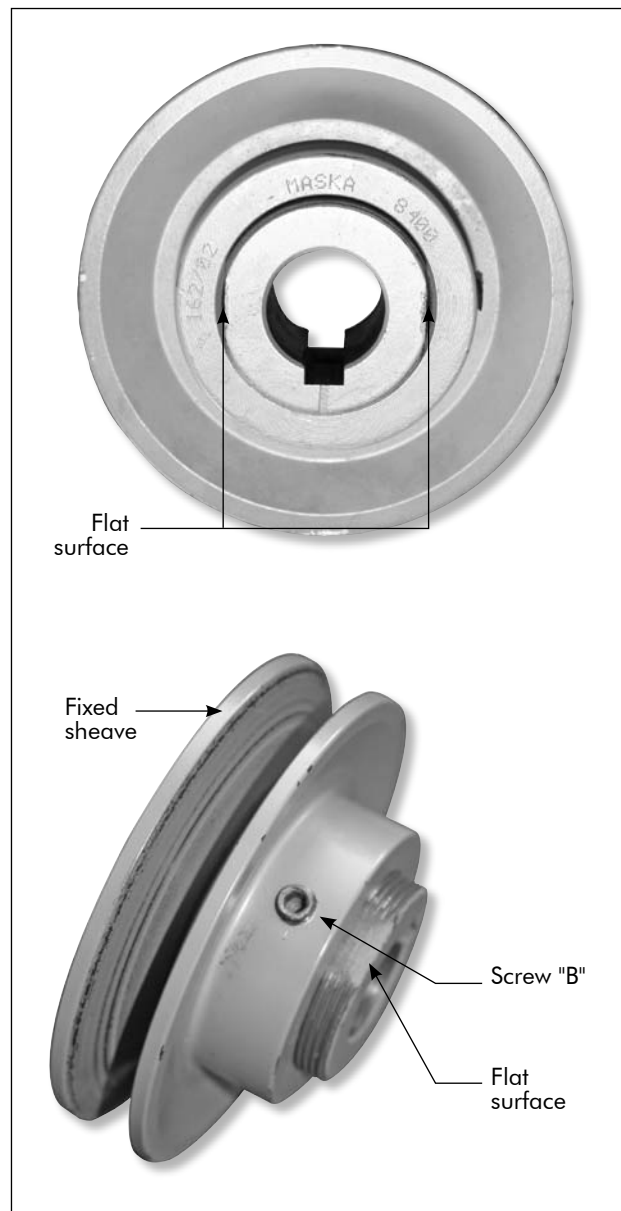

10 - Maintenance

It is recommended to proceed to the following maintenance works in order to ensure a good operation of the unit.



Caution

Before performing any maintenance operation, disconnect the unit main power supply.

10.1 - Air filter

Filters should be frequently cleaned to avoid clogging. They should be inspected every 3 or 4 months under normal operating conditions and be replaced if necessary.

Unit should never be run without filter.

The filters can be removed for cleaning or replacement, through the bottom or the side of the unit (see drawings below).

Filter removal through the bottom

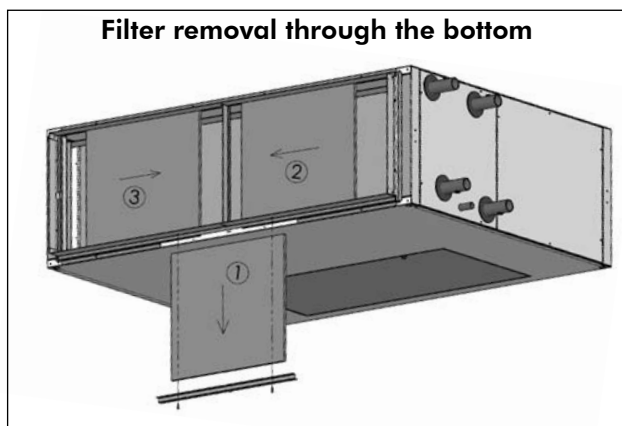

Filter removal through the side

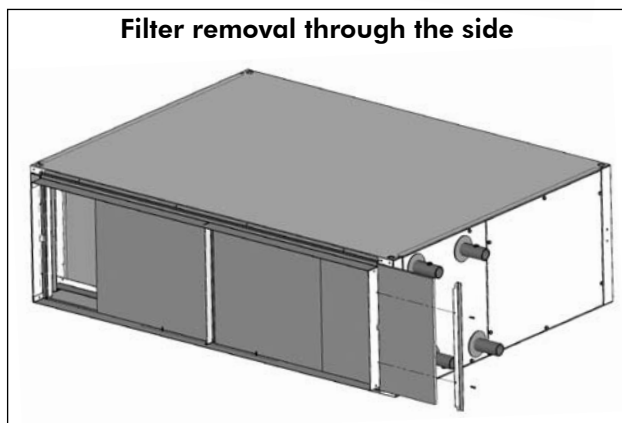

Clips

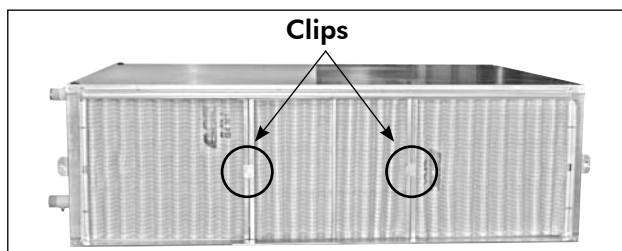

Note : In case the filters are to be removed from the bottom, take off the clips on the filters in order to be able to remove them from the casing.

10.2 - Condensate drain pan

The condensate pan must be checked periodically to make sure that drain piping is not obstructed.

If required, it must be cleaned and rinsed.

The fan motor assembly bottom panel allows for easy access, if there is no heating coil located downstream the cooling coil, to condensate drain pan for cleaning.

10.3 - Coils

Check that coil fins are not clogged or damaged.

To avoid mouldiness of coils caused by an accumulation of fine dusts, it is recommended to clean them frequently. If necessary, comb the coil fins with an appropriate tool.

Coils removal

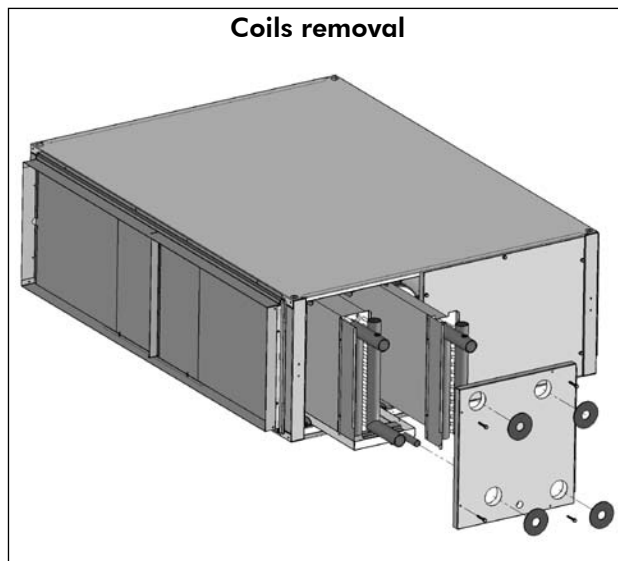

Care must be taken not to damage the fins while cleaning them.

The coils can be removed for cleaning as shown on the drawing below.

10.4 - Fan motor assembly

There is no particular maintenance on fan motor assembly. The units are equipped with permanently lubricated fan motor bearings. It is not necessary to add oil. However, during periodic maintenance, check that fan wheel rotates freely without any friction.

If the fan motor overload protection is tripped, wait for safety automatic reset and try to find out the cause of overload protection tripping.

Follow the instructions below to remove the motor and fans for replacement :

Step 1 : Access panels removal

Disconnect the unit power supply. According to the access condition, remove either the service side panel and the opposite panel or the service side panel and the fan motor assembly access panel.

Step 2 : Motor removal

Take away the drive belt, then the fixing screws from the motor platform. Push this platform upward to take it from the fans support rails.

10 - Maintenance (continued)

Step 3 : Fans dismantling

Remove the first and the second support rails of the fans, after releasing the 3 fixing screws of the rails to the vibration isolators, and the 6 fixing screws of the fans to the support rails.

Note : On sizes 5.05 and 6.05, it is not necessary to remove the rails, since the set of fans and rails can go through the service side access.

Step 4 : Fans removal

Pull backwards the fans before taking them out through the service side access.

10.5 - Electrical connections

Re-tighten periodically the electrical connections.

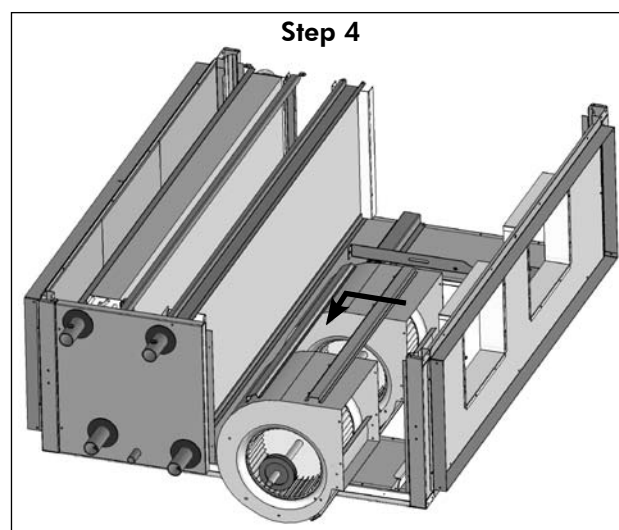
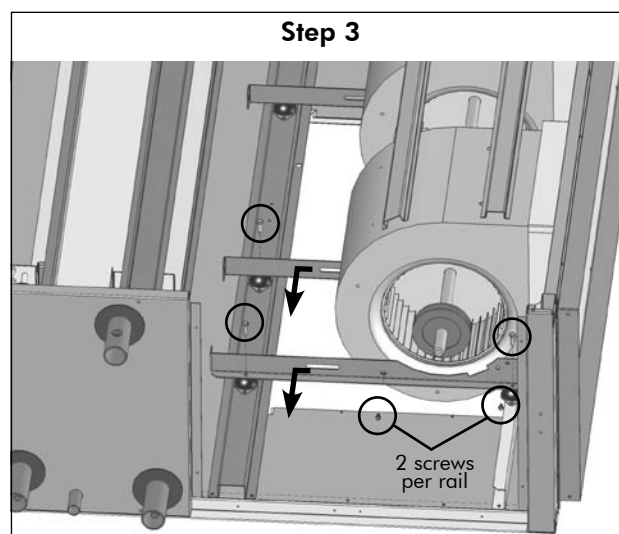
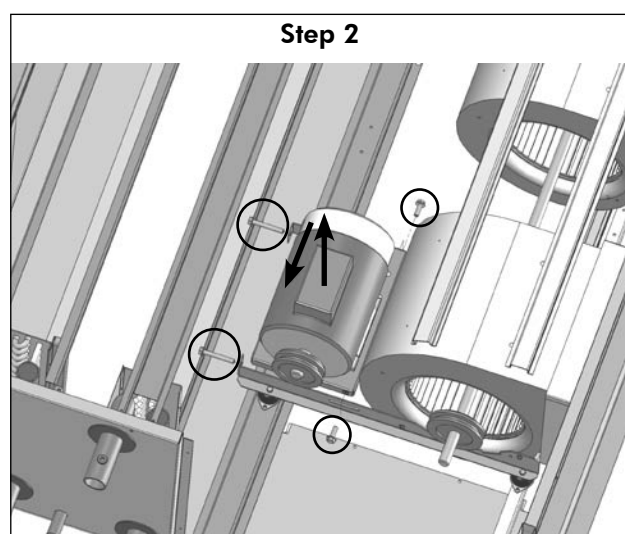
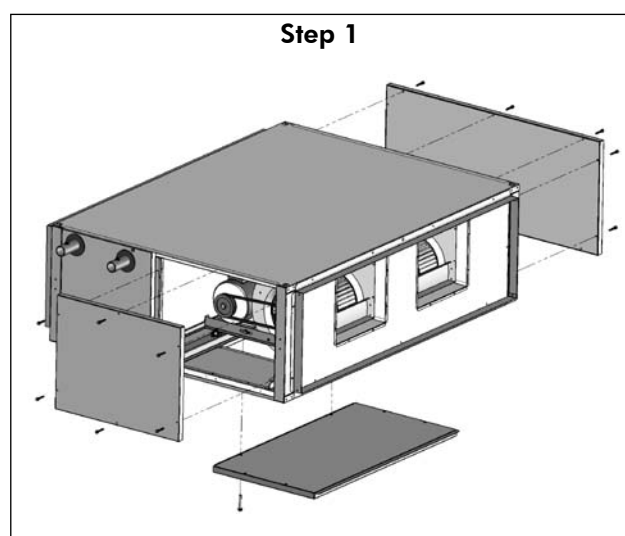

10.6 - Water quality

It is not the manufacturer's policy to make recommendations in terms of water treatment (please contact a specialised water treatment company).

However, given the critical nature of this subject, particular care should be taken to ensure that, if treatment is required, it works effectively.

Using untreated or unsuitable water leads to excessive clogging inside the coil tubes (earth and mud deposits, corrosion, etc.) with major consequences on the thermal efficiency of the unit and irreversible damage to the equipment.

The manufacturer and its representative decline all responsibility in the event of untreated or incorrectly treated water being used.

Notes

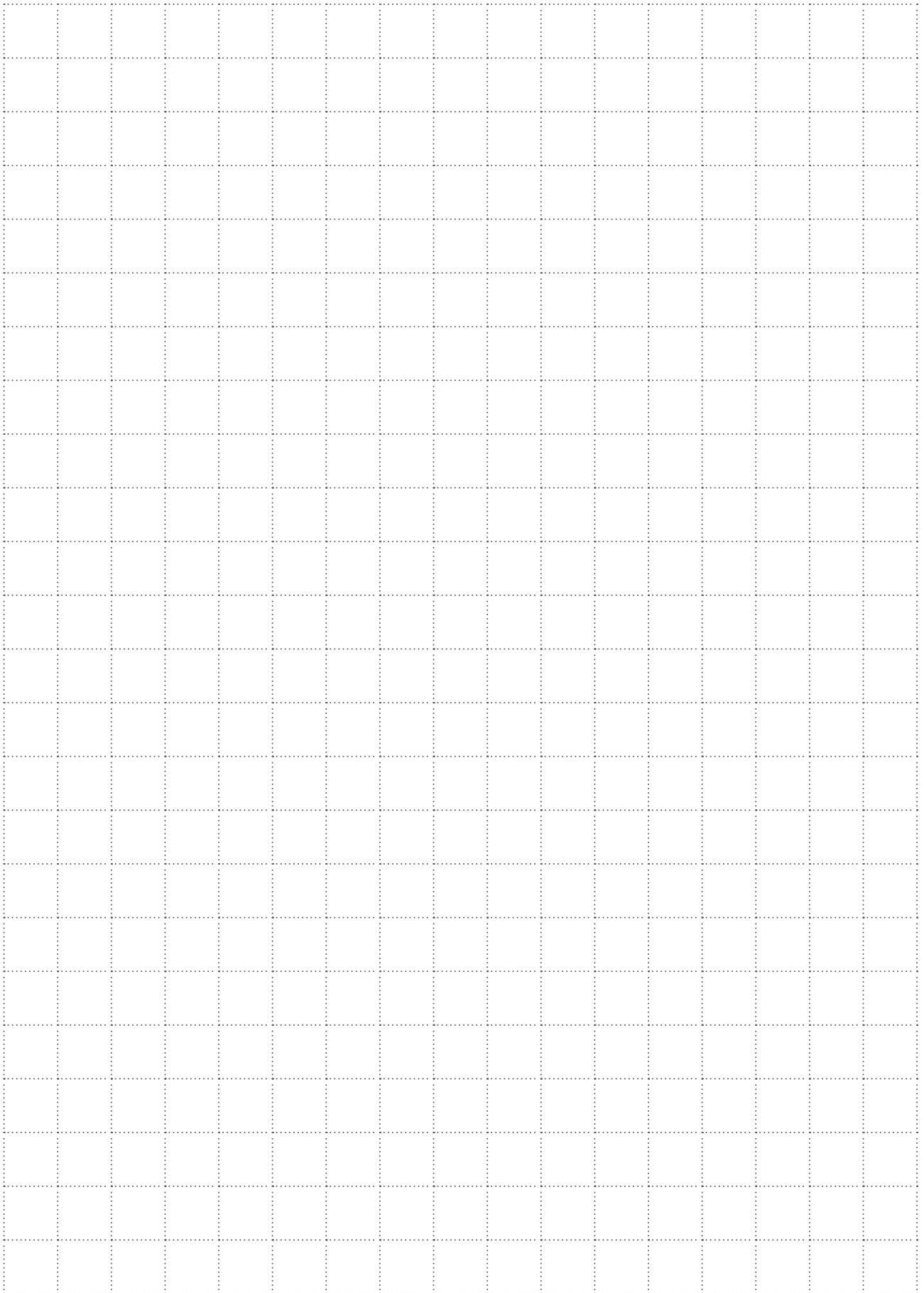

Wesper S.A.S.

42 cours Jean-Jaurès
17800 PONS - FRANCE

Tél. : +33-5 46 92 33 33

Fax : +33-5 46 91 38 33

www.wesper.com

As part of our ongoing product improvement programme, our products are subject to change without prior notice. Non contractual photos.

Dans un souci d'amélioration constante, nos produits peuvent être modifiés sans préavis. Photos non contractuelles.

Your distributor / Votre agent commercial :

